

# MITSUBISHI

## 三菱工業用ミシン部品カタログ

## Industrial Sewing Machine Parts Catalog

Model PLK-G5045R-C

	目次	CONTENTS	Page
A	全 体 構 成	Construction	1
B	本 体 関 係 (1)	Arm bed & its accessories(1)	2
C	本 体 関 係 (2)	Arm bed & it's accessories(2)	4
D	本 体 関 係 (3)	Arm bed & it's accessories(3)	6
E	縫 い 機 構 (1)	Sawing mechanism(1)	8
F	縫 い 機 構 (2)	Sawing mechanism(2)	10
G	中 押 え 機 構 (1)	Presser bar lifting mechanism(1)	12
H	中 押 え 機 構 (2)	Presser bar lifting mechanism(2)	14
J	糸 切 り 機 構	Thread trimming mechanism	16
K	X-Y テーブル 機 構 (1)	X-Y table mechanism	18
L	X-Y テーブル 機 構 (2)	X-Y table mechanism(2)	20
M	ワ イ パ ー 機 構	Wiper mechanism	22
N	給 油 機 構	Oil lubrication mechanism	24
P	配 線 配 管 関 係	Cable component & Pneumatic control unit	26
Q	テ ー ブ ル 関 係	Table & Stand	28
R	付 属 品 (1)	Accessories(1)	30
S	付 属 品 (2)	Accessories(2)	32
	索 引	Index	34

## 部品コードの採番形式

### MITSUBISHI SPARE PARTS No. Designation system

#### 1. 部品コードについて CONCERNING PARTS CODE.

部品をご注文される場合は、部品コードをお知らせください。

Please inform the part number, when these parts are ordered.

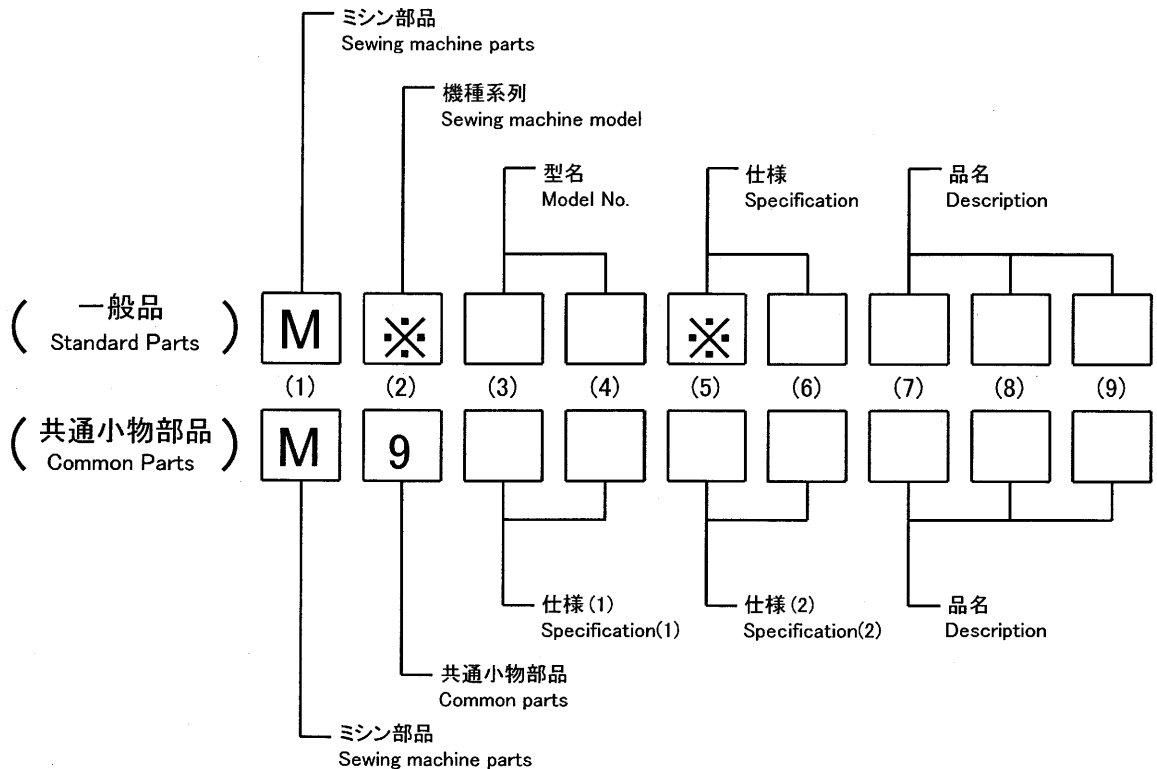

#### 【 例 Example 】

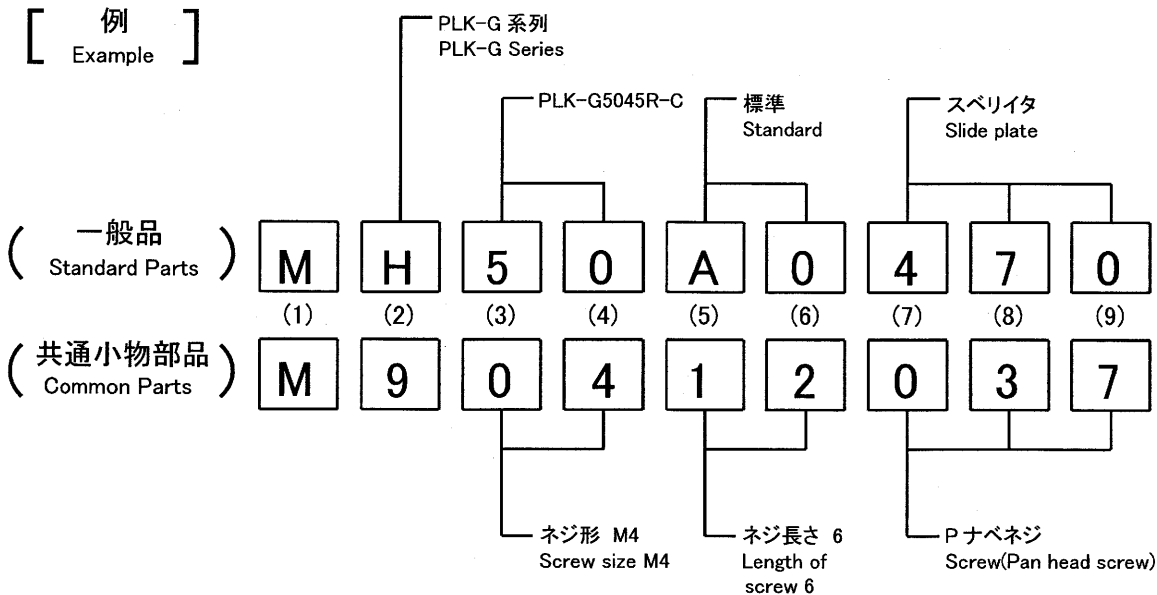

#### 2. 変更マークについて CONCERNING MODIFICATION MARK.

変更マーク欄に \* 記号のある部品は、形状、寸法などの変更履歴がありますので、ご注文の際にはご使用の製品の製造番号と合わせてご覧ください。

The parts marked with \* in the modification column has been changed the shape or size etc. So when these modified parts are ordered please inform the serial number of the sewing machine.

注：一般品についての機種型名は、その部品が最初に使用された機種型名を示します。従って長期にわたる場合は、機種の改廃が行われるため、当初の機種以外の機種で使用されている場合があります。

Sewing machine Models, of Standard Parts are Indicated model of these parts are registered firstly. Parts are used for not only the indicated model, but also another models, in reason of New development, improvement after.

**A** 全体構成  
CONSTRUCTION

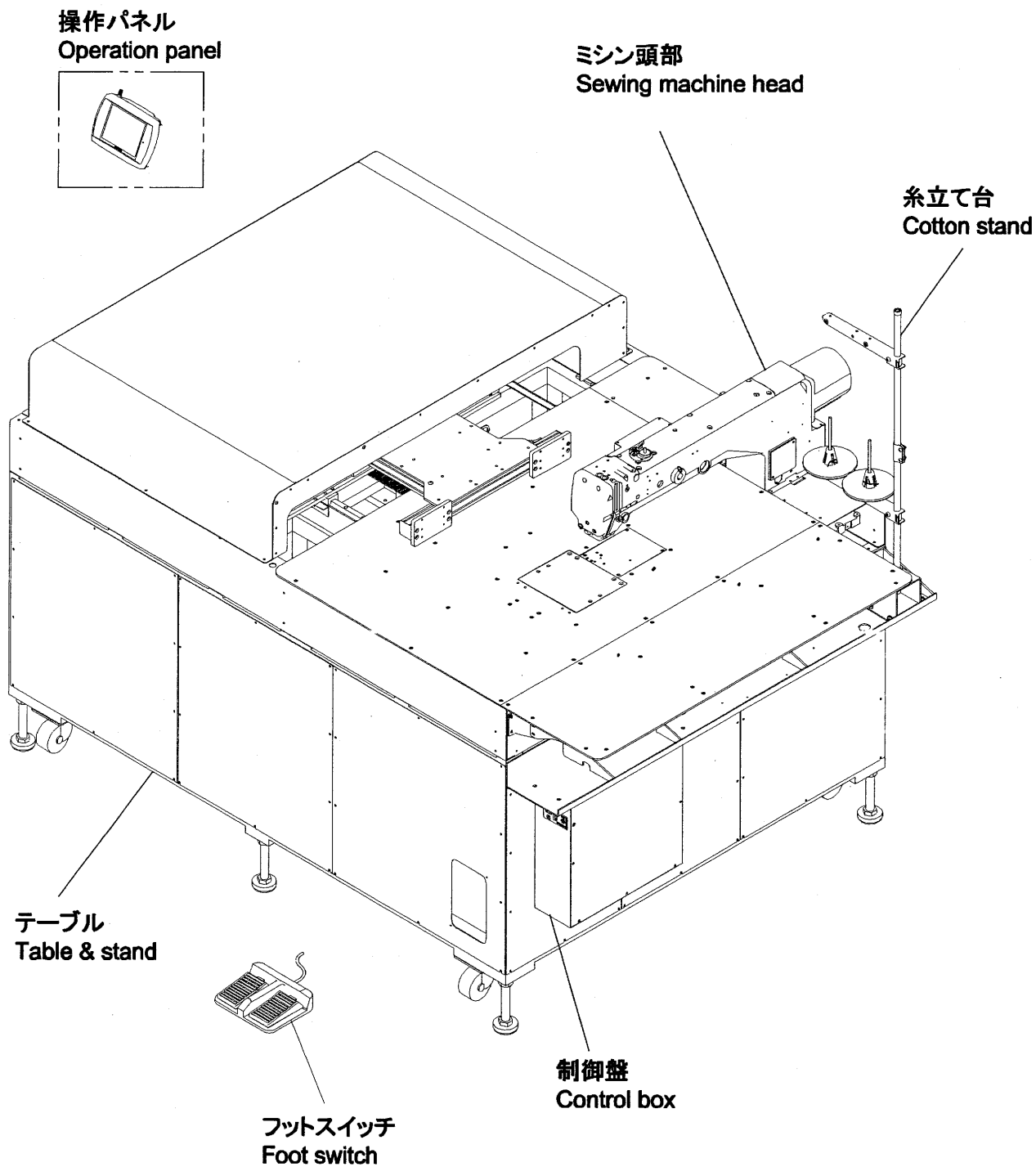

注1： Fig.No.の採番していない部品は単体で支給することは出来ません。セットにて支給いたします。

Remarks 1) The parts which Fig.No. are not marked are not available individually.  
It can be supplied with the whole component.

**B** 本体関係(1)  
**ARM BED & IT'S ACCESSORIES(1)**

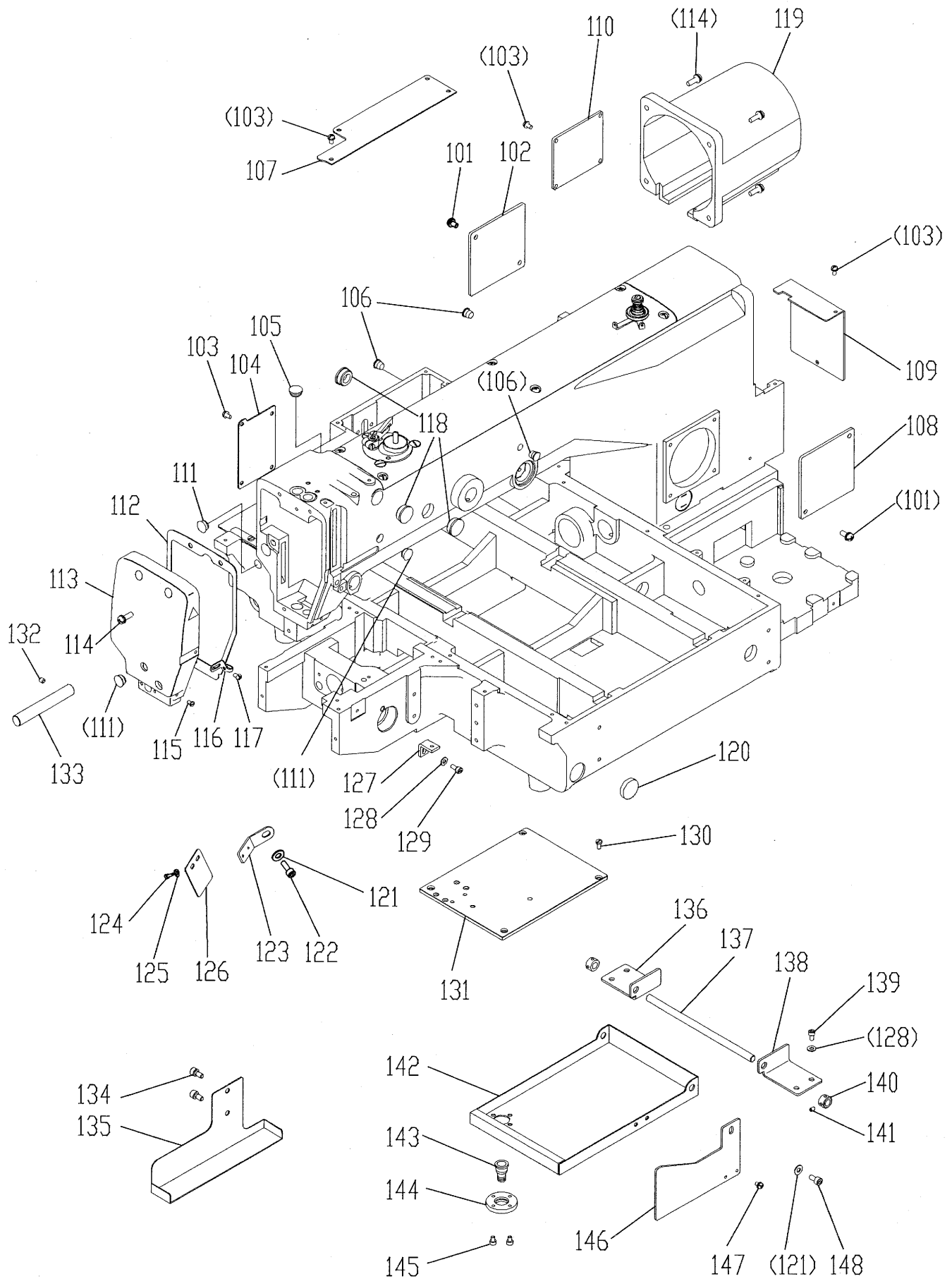

## [B] 本体関係(1)

## ARM BED &amp; IT'S ACCESSORIES(1)

Fig no.	変更 Mod.	部品コード Parts no.	品名	Description	数量 Amt. Req.
B 101		M91067004	SW-PWプラマイナヘネジ M5X10	Screw M5X10	4
B 102		MH50A4339	アームソクメンカバー-A	Cover A	1
B 103		M91054004	SW-PWプラマイナヘネジ M4X8	Screw M4X8	14
B 104		MH10A0742	フタ	Cover	1
B 105		M91304080	ゴムセン φ13	Rubber plug φ13	2
B 106		M90883080	ゴムセン φ8.8	Rubber plug φ8.8	3
B 107		MH27A0339	アームジョウブカバー	Cover	1
B 108		MH50A5339	アームソクメンカバー-B	Cover	1
B 109		MH50A6339	アームソクメンカバー-C	Cover	6
B 110		MH50A7339	アームソクメンカバー	Cover	1
B 111		M91182080	ゴムセン φ11.8	Rubber plug φ11.8	4
B 112		MH10A0691	ガスケット	Gasket	1
B 113		MH10A0830	フェイスカバー	Face cover	1
B 114		M91333004	SW-PWプラマイナヘネジ M5X16	Screw M5X16	7
B 115		M90908003	マルヒラネジ 9/64(40)X6	Screw 9/64(40)X6	1
B 116		MG43A1181	トアンナイ	Thread guide	1
B 117		M91011004	プラマイナヘネジ M4X6	Screw M4X6	1
B 118		M91910080	ゴムセン φ19	Rubber plug φ19	3
B 119		MH27A1849	シュンクモーターカバー	Main shaft motor cover	1
B 120		MH50A0418	ゴムワッシャ	Rubber washer	1
B 121		M90511050	ミガキサガネ 5	Washer 5	2
B 122		M95005017	セフティソケット M5X10	Safety socket bolt M5X10	1
B 123		MH50A5601	ミラートリツケイタ	Miller bracket	1
B 124		M90316050	ミガキサガネ 3	Washer 3	2
B 125		M94003017	セフティソケット M3X6	Safety socket bolt M3X6	2
B 126		MH50A0694	ミラー	Miller	1
B 127		MB62A4601	トリツケイタ	bracket	2
B 128		M90421050	ミガキサガネ 4	Washer 4	6
B 129		M94007017	セフティソケット M4X12	Safety socket bolt M4X12	2
B 130		M90990002	ヒラネジ M4X8	Screw M4X8	4
B 131		MH50A0470	スベリイタ	Slide plate	1
B 132		M95002020	ロッカクアナツキメネジ M5X6	Screw M5X6	2
B 133		MH50A0454	シャフト	Shaft	2
B 134		M95003017	セフティソケット M5X8	Safety socket bolt M5X8	2
B 135		MH50A8339	オイルガード	Oil guard	1
B 136		MH50A2758	ブラケットヒタリ	Bracket L	1
B 137		MH50A1454	シャフト	Shaft	1
B 138		MH50A3758	ブラケットミキ	Bracket R	1
B 139		M95018021	ロッカクアナツキボルト M4X8	Screw M4X8	4
B 140		ME20A0352	セットカラー	Set collar	2
B 141		M91055020	ロッカクアナツキメネジ M4X4	Screw M4X4	4
B 142		MH50A1131	オイルパン	Oil pan	1
B 143		MF13A0377	キュウユグチ	Oil port	1
B 144		MH50A0165	アダプタ	Adaptor	1
B 145		M94001021	ロッカクアナツキボルト M4X6	Screw M4X6	4
B 146		MH50A0429	ササエイタ	Plate	1
B 147		M91058004	SW-PWプラマイナヘネジ M4X6	Screw M4X6	2
B 148		M95002021	ロッカクアナツキボルト M5X10	Screw M5X10	1

**C 本体関係(2)**  
**ARM BED & IT'S ACCESSORIES(2)**

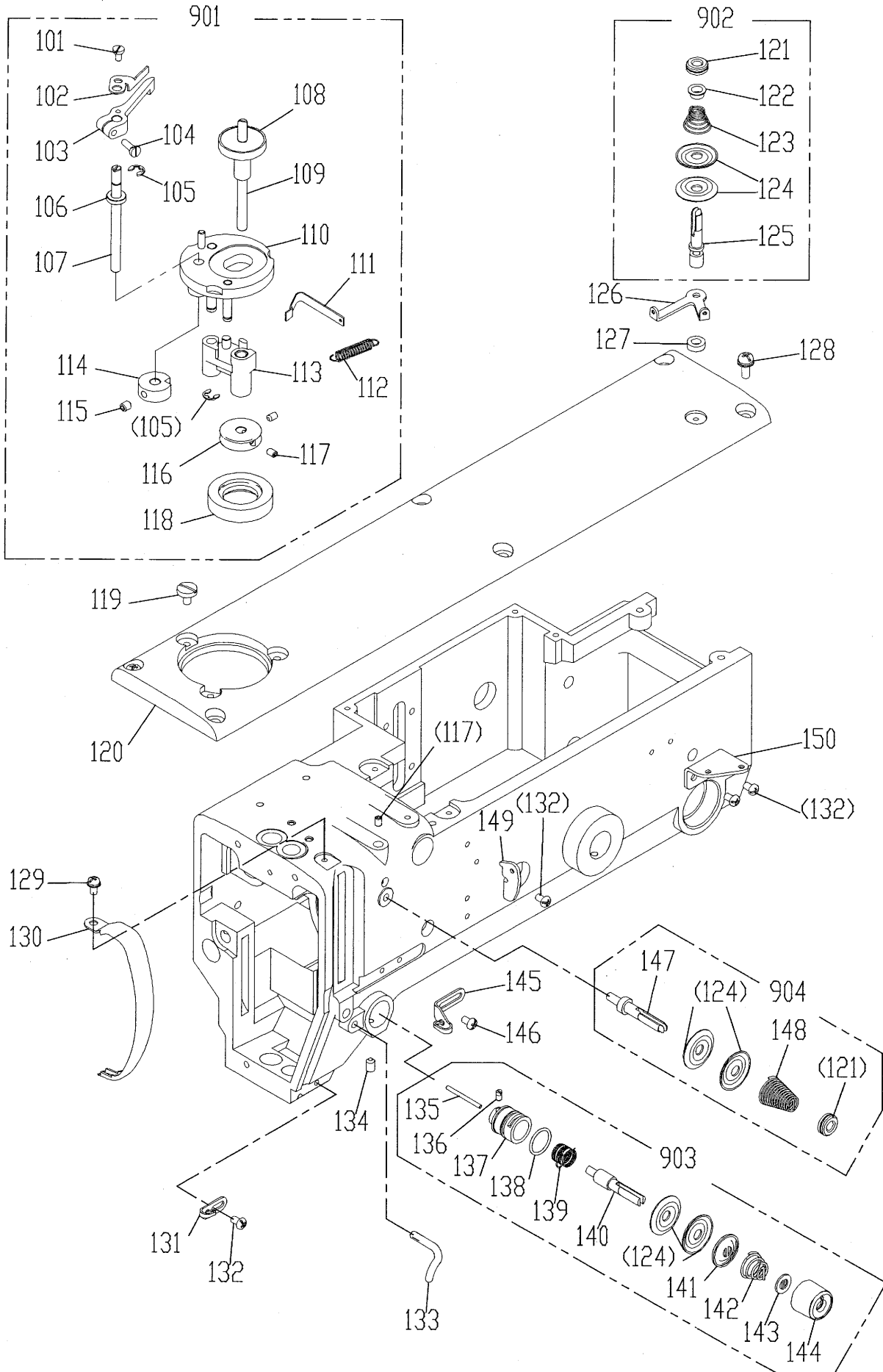

## [C] 本体関係(2)

## ARM BED &amp; IT'S ACCESSORIES(2)

Fig no.	変更 Mod.	部品コード Parts no.	部品名	Description	数量 Amt. Req.
C 101		M90920002	ヒラネジ 9/64(40)X6.5	Screw 9/64(40)X6.5	1
C 102		MF13A0551	チョウセツイタ	Adjustment plate	1
C 103		MF13A0950	レバー	Lever	1
C 104		M90939002	ヒラネジ 9/64(40)X11	Screw 9/64(40)X11	1
C 105		M70535065	Eが外メ 5	E-type stop ring 5	2
C 106		MF13A0750	ブッシュ	Spacer	1
C 107		MH10A0348	カムジク	Cam shaft	1
C 108		MF13A0793	ホビンザ	Bobbin cushion	1
C 109		MH27A0191	トマキジク	Bobbin winder shaft	1
C 110		MF13A2191	トマキダイクミタテ	Bobbin winder base assy	1
C 111		MF13A0192	イタバネ	Leaf spring	1
C 112		MF13A0572	ツルマキバネ	Spring	1
C 113		MH50A0191	トマキウテクミタテ	Bobbin winder shaft holder assy	1
C 114		MF13A0350	トマキカム	Bobbin winder cam	1
C 115		M95002020	ロツカクアナツキトメネジ M5X6	Screw M5X6	1
C 116		MH10A0194	トマキグルマ	Bobbin winder wheel	1
C 117		M91053020	ロツカクアナツキトメネジ M4X6	Screw M4X6	3
C 118		MH10A0417	ゴムワ	Rubber ring	1
C 119		M91150003	マルヒラネジ 11/64(40)X8	Screw 11/64(40)X8	3
C 120		MH27A0600	トップカバー	Top cover	1
C 121		M91602046	ツマミナット	Thumb nut	2
C 122		MM11A0702	ハネアンナイ	Spring guide	1
C 123		MM11A0245	エンスイバネ	Thread tension spring	1
C 124		MF10A0555	チョウシザラ	Thread tension discs	6
C 125		MS14A0553	チョウシホウ	Thread tension stud	1
C 126		MS14A1180	トアンナイ	Thread guide	1
C 127		MG75A1476	スペーサ	Spacer	1
C 128		M91331004	SW-PWフライナイバネジ M5X12	Screw M5X12	6
C 129		M91054004	SW-PWフライナイバネジ M4X8	Screw M4X8	1
C 130		MH10A0584	テンビンカバー	Thread take-up lever guard	1
C 131		MF10A0181	トアンナイ	Thread guide	1
C 132		M91011004	フライナイバネジ M4X6	Screw M4X6	4
C 133		MF70A1180	トアンナイ	Thread guide	1
C 134		M95004020	ロツカクアナツキトメネジ M5X8	Screw M5X8	1
C 135		M90204060	ピン	Pin	1
C 136		M90901002	ヒラネジ 9/64(40)X4	Screw 9/64(40)X4	1
C 137		MF10A0709	ブッシュ	Regulator casing	1
C 138		M91501085	Oリング	O-ring	1
C 139		MF10A0187	イトリバネ	Thread take-up spring	1
C 140		MF10A0553	チョウシホウ	Thread tension stud	1
C 141		MH40A0556	チョウシザラオサエ	Disc retaining plate	1
C 142		MN52A1245	エンスイバネ	Thread tension spring	1
C 143		MT60A0802	マワリトメ	Thumb nut revolution stopper	1
C 144		M91610046	ツマミナット	Thumb nut	1
C 145		MG43A0181	トアンナイ	Thread guide	1
C 146		M91011004	フライナイバネジ M4X6	Screw M4X6	1
C 147		MH10A0553	チョウシホウ	Thread tension stud	1
C 148		MH10A0245	エンスイバネ	Thread tension spring	1
C 149		MH10A2181	トアンナイ	Thread guide	1
C 150		MH10A3181	トアンナイ	Thread guide	1
C 901		MH27E0190	トマキソウチクミタテ	Bobbin winder complete	1
C 902		MS14E0180	チョウセツキクミタテ	Thread tension Regulator assy	1
C 903		MH10E0210	チョウセツキクミタテ	Thread tension Regulator assy	1
C 904		MH27E0550	トチョウセツキクミタテ	Thread tension Regulator assy	1

**D 本体関係(3)**  
**ARM BED & IT'S ACCESSORIES(3)**

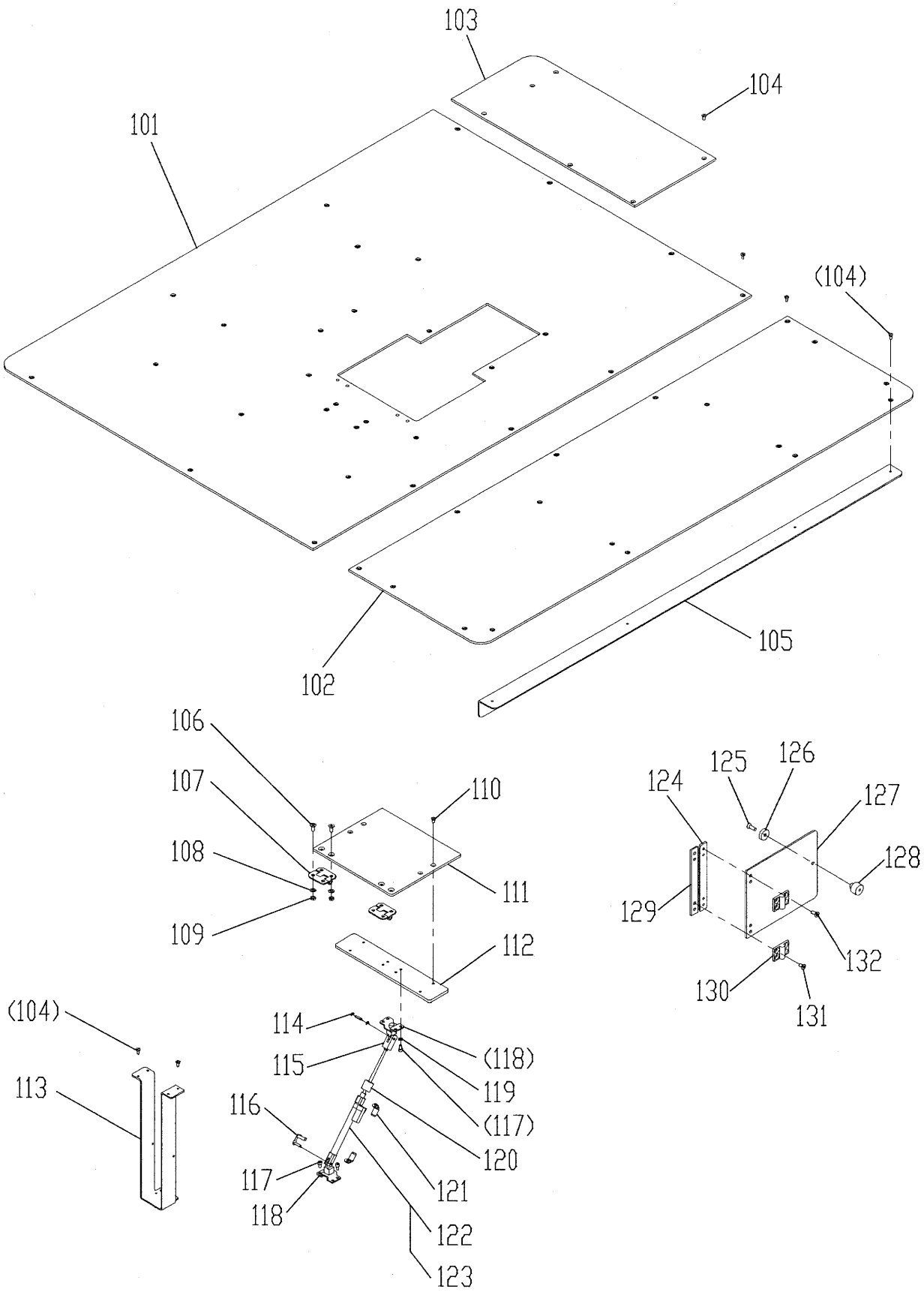



## [D] 本体関係(3)

## ARM BED &amp; IT'S ACCESSORIES(3)

Fig no.	変更 Mod.	部品コード Parts no.	品名	Description	数量 Amt. Req.
D 101		MH50A1470	スベリ板 A	Slide plate A	1
D 102		MH50A2470	スベリ板 B	Slide plate B	1
D 103		MH50A3470	スベリ板 C	Slide plate C	1
D 104		M90990002	ヒラネジ M4X8	Screw M4X8	53
D 105		MH50A0359	ウイト	Weight	1
D 106		M90522037	Pサラネジ(SUS) M5X10	Screw M5X10	8
D 107		MH50A0739	ヒンジ	Hinge	2
D 108		M90522050	サラバネサガネ 5	Spring washer 5	8
D 109		M91384045	トメナット M5	Nut M5	8
D 110		M90449037	Pサラネジ M4X8	Screw M4X8	4
D 111		MH50A0742	カイヘイフタ	Flap plate	1
D 112		MH50A0477	ストップ板	Stopper plate	1
D 113		MH50A6601	シリンダトリツケイタ	Cylinder bracket	1
D 114		M90513065	Eガ外メワ 2.5	E-type retaining ring	2
D 115		MH50A0571	フタヤマナックルジョイント	Knuckle joint	1
D 116		M90323063	クビスピン	Pin	1
D 117		M94002017	セフティソケット M4X8	Safety socket bolt M4X8	8
D 118		MH50A0361	Tカナゲ	T-bracket	2
D 119		M90422050	コサガネ 4	Washer 4	8
D 120		MH50A0731	ウレタンクッション	Urethane bumper	1
D 121		MB61A1571	エルボユニオン	Fitting	2
D 122		MH50A0434	エアシリンダクミタテ	Air cylinder assy	1
D 123		MH50A1508	エンチョウケーブルクミタテ	Connection wire assy	1
D 124		MH50A0640	ネジ板	Nut plate	1
D 125		M90523037	Pサラネジ M5X16	Screw M5X16	1
D 126		MH50A0809	マグネット	Magnet	1
D 127		MH50A1742	ソクメンフタ	Side cover	1
D 128		MH50A0650	アヤメローレットノブ	Knob	1
D 129		MH50A1476	スペーサ	Spacer	1
D 130		MH50A1739	ヒンジ	Hinge	2
D 131		M91500010	Pサラネジ M5X12	Screw M5X12	4
D 132		M91320004	Pサラネジ M5X10	Screw M5X10	4

**E 縫い機構(1)**  
**SEWING MECHANISM(1)**

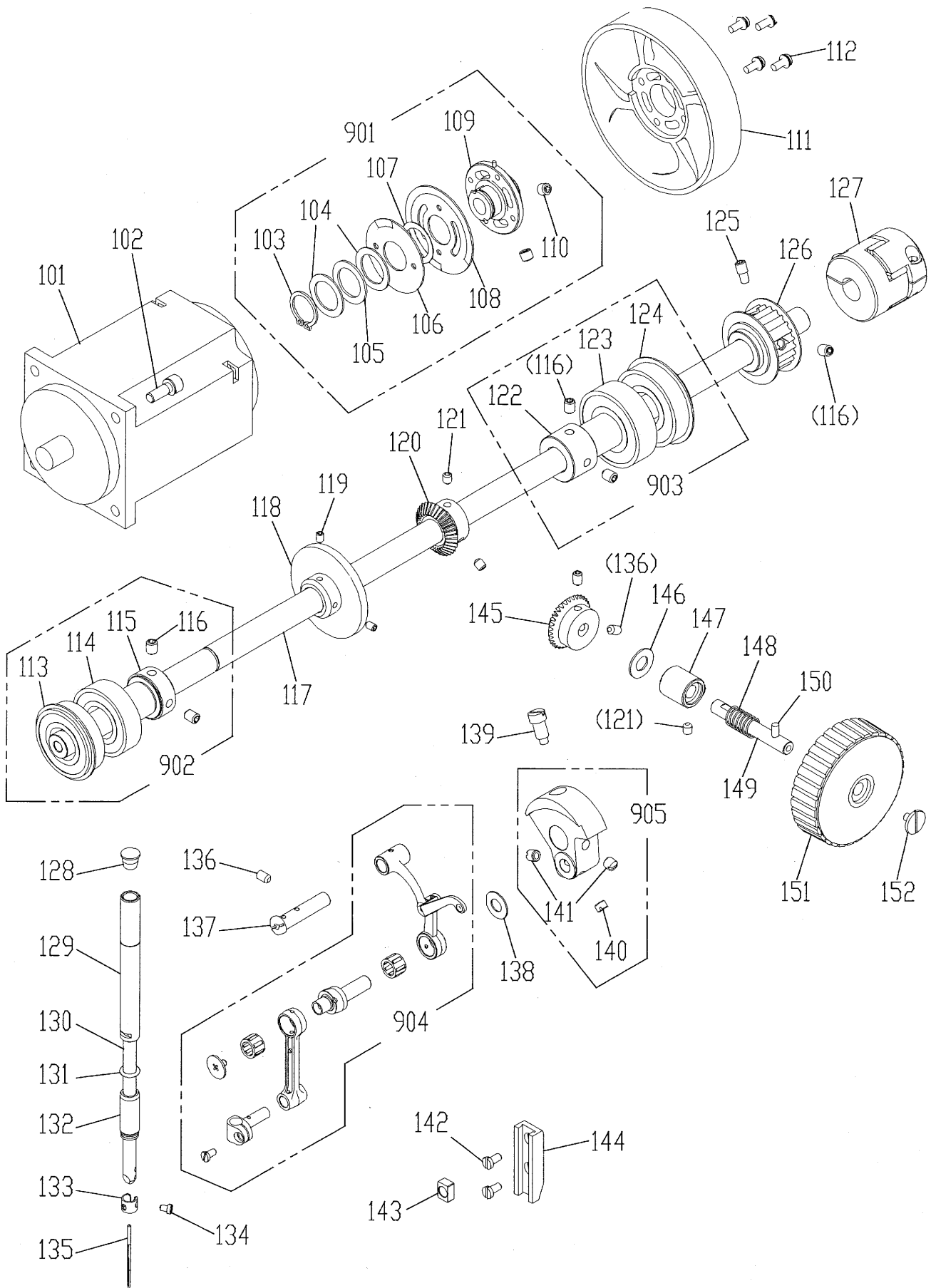

## [E]縫い機構(1)

## SEWING MECHANISM(1)

Fig no.	変更 Mod.	部品コード Parts no.	品名	Description	数量 Amt. Req.
E 101		MH10E2848	シュジクモータ	Main shaft motor	1
E 102		M96001017	セフティソケット M6X16	Safety socket bolt M6X16	4
E 103		M90337065	C型外メ 18	C-type retaining ring 18	1
E 104		MF17A1476	スペーサ B	Spacer B	2
E 105		M93016050	ナミワッシャ	Wave washer	1
E 106		MH10A1694	ハンシャパン (ウエ)	Command disk (up)	1
E 107		MF17A2476	スペーサ A	Spacer A	1
E 108		MH10A0694	ハンシャパン (シタ)	Command disk (down)	1
E 109		MH10A0750	ブッシュクミ	Bushing assy	1
E 110		M91609020	ロッカアナツキトメネジ 1/4(40)X5.5	Screw 1/4(40)X5.5	2
E 111		MH50A0682	プーリ	Pulley	1
E 112		K14S90203410	SW-PW Pナネジ M4X10	Screw M4X10	4
E 113		MH10A1456	ジクウケ	Ball bearing	1
E 114		MH10A0456	ジクウケ	Ball bearing	1
E 115		MH10A1750	ブッシュ	Bushing	1
E 116		M91650020	ロッカアナツキトメネジ M6X8	Screw M6X8	5
E 117		MH27A0230	ウワジク	Upper shaft	1
E 118		MS14A0682	プーリ	Pulley	1
E 119		M91053020	ロッカアナツキトメネジ M4X6	Screw M4X6	2
E 120		MH10A1722	ウワジクマイタキヤ	Gear	1
E 121		M95002020	ロッカアナツキトメネジ M5X6	Screw M5X6	3
E 122		MH27A2750	ブッシュ	Bushing	1
E 123		MH27A0456	ジクウケ	Ball bearing	1
E 124		MN10A1456	ジクウケ	Ball bearing	1
E 125		M96001005	ロッカアナツキトメネジボウサキ M6X6	Screw M6X6	1
E 126		MF13A0767	タイミングベルトグルマウエ	Belt pulley (upper)	1
E 127		MH10A0364	カップリング	Coupling	1
E 128		M90883080	ゴムセン φ8.8	Rubber plug φ8.8	1
E 129		MH10A0663	ハリボウメタル (ウエ)	Needle bar bushing (upper)	1
E 130		MH27A0660	ハリボウ	Needle bar	1
E 131		M90500085	リング	O-ring	1
E 132		MH27A0664	ハリボウメタル (シタ)	Needle bar bushing (lower)	1
E 133		MG42A0181	イトアンナイ	Thread guide	1
E 134		M90815002	ヒラネジ 1/8(44)X4.5	Screw 1/8(44)X4.5	1
E 135		MS02A0128	ミシンハリ DPX17#18	Needle DPX17#18	1
E 136		M95004020	ロッカアナツキトメネジ M5X8	Screw M5X8	3
E 137		MH10A0530	ダンツキジクミタテ	Stepped shaft assy	1
E 138		M90836050	ワッシャ	Washer	1
E 139		M91802006	ヒラネジボウサキ 9/32(28)	Set screw 9/32(28)	1
E 140		M91602001	トメネジ 1/4(40)X4	Screw 1/4(40)X4	1
E 141		M91606001	トメネジ 1/4(40)X6	Screw 1/4(40)X6	2
E 142		M90990002	ヒラネジ M4X8	Screw M4X8	2
E 143		MF10A0325	カクコマ	Square block	1
E 144		MS01A0155	アンナイダイ	Guide bracket	1
E 145		MH10A0722	マイタキヤ	Gear	1
E 146		MH10A0416	カンショウゴム	Rubber cushion	1
E 147		MH27A0833	メタル	Bushing	1
E 148		MH10A0572	ツルマキハネ	Spring	1
E 149		MH27A1454	ジク	Shaft	1
E 150		M90406064	スプリングピン φ4X14	Spring pin φ4X14	1
E 151		ME25A0682	プーリ	Pulley	1
E 152		M91119002	ヒラネジ 11/64(40)X6.8	Screw 11/64(40)X6.8	1
E 901		MH10A4750	ブッシュクミタテ	Bushing assy	1
E 902		MH10E0456	ジクウケクミタテ (マエ)	Ball bearing assy (front)	1
E 903		MH27A2456	ジクウケクミタテ (ウシロ)	Ball bearing assy (rear)	1
E 904		MH27E0580	テンピンハリクミタテ	Thread take-up lever assy	1
E 905		MH27E0383	クランククミタテ	Crank assy	1

**F** 縫い機構(2)  
SEWING MECHANISM(2)

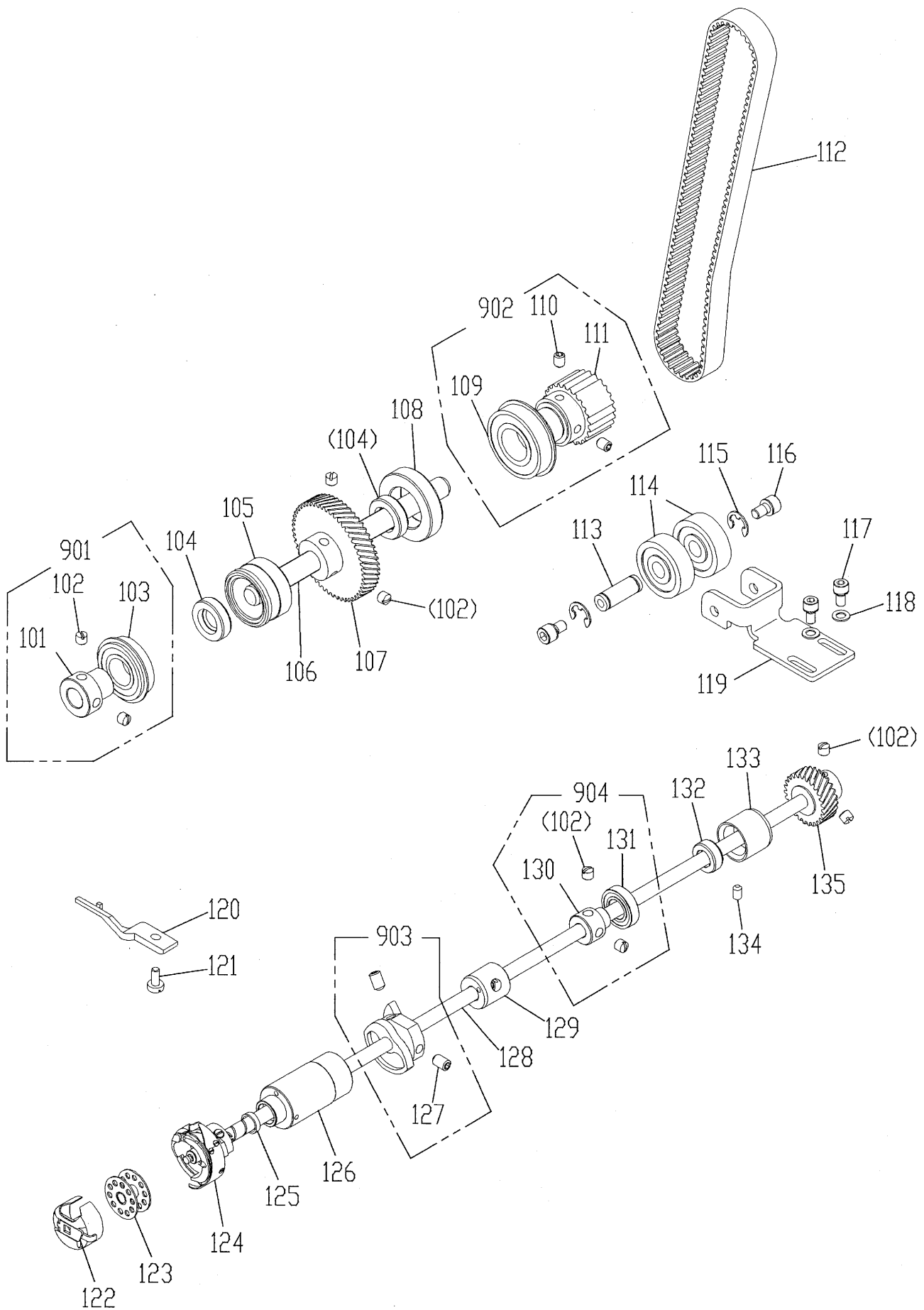

## [F]縫い機構(2)

## SEWING MECHANISM(2)

Fig no.	変更 Mod.	部品コード Parts no.	品名	Description	数量 Amt. Req.
F 101		MF13A9750	ブッシュ	Bushing	1
F 102		M91606001	トメネジ 1/4(40)X6	Screw 1/4(40)X6	8
F 103		MF13A0456	ジクウケ	Ball bearing	1
F 104		M91200086	オイルシール	Oil seal	2
F 105		MH27A4750	ブッシュ	Bushing	1
F 106		MH27A1450	シタジク (ヒタリ)	Lower shaft (L)	1
F 107		MF13A1683	ハスバハグルマタイ	Gear (large)	1
F 108		MF13A4750	ブッシュ	Bushing	1
F 109		MN70A2456	ジクウケ	Ball bearing	1
F 110		M91650020	ロツカクアナツキトメネジ M6X8	Screw M6X8	2
F 111		MF13A2767	タイミングベルトグルマシタ	Belt pulley (lower)	1
F 112		MH27A0523	タイミングベルト	Timing belt	1
F 113		MH27A2454	テシヨナーシャフト	Shaft	1
F 114		MH27A3456	ジクウケ	Ball bearing	2
F 115		M90604065	Eガ外メワ 8	E-type retaining ring 8	2
F 116		M96008017	セフティソケット M6X10	Safety socket bolt M6X10	2
F 117		M95002017	セフティソケット M5X12	Safety socket bolt M5X12	2
F 118		M90512050	コザガネ 5	Washer 5	2
F 119		MH27A0770	テシヨナーベース	Base	1
F 120		MF20A0229	ウチガトメ	Hook positioner	1
F 121		M91118002	ヒラネジ 11/64(40)X10	Screw 11/64(40)X10	1
F 122		MG44E0125	ホビンケース	Bobbin case	1
F 123		MF25B0123	ホビン	Bobbin	1
F 124		ME20A0120	カマクミタテ	Hook complete	1
F 125		M90800086	オイルシール	Oil seal	1
F 126		MS10A0451	シタジクメタル (ヒタリ)	Hook shaft bushing (L)	1
F 127		M91602020	ロツカクアナツキトメネジ 1/4(40)X10	Screw 1/4(40)X10	2
F 128		MH27A0450	シタジク	Lower shaft	1
F 129		MH27A0453	シタジクメタル (ナカ)クミタテ	Hook shaft bushing (M) assy	1
F 130		MH27A5750	ブッシュ	Bushing	1
F 131		MF13A1456	ジクウケ	Ball bearing	1
F 132		M90804086	オイルシール	Oil seal	1
F 133		MF13A0452	シタジクメタル (ミキ)	Hook shaft bushing (R)	1
F 134		M95004020	ロツカクアナツキトメネジ M5X8	Screw M5X8	1
F 135		MF13A0683	ハスバハグルマショウ	Gear (small)	1
F 901		MF13E6456	ジクウケクミタテ	Ball bearing assy	1
F 902		MF13E1767	タイミングベルトグルマシタクミタテ	Belt pulley (lower) assy	1
F 903		MF01E0350	イキリカム	Thread trimmer cam	1
F 904		MH27A4456	ジクウケクミタテ	Hook shaft bushing (R) assy	1

**G** 中押え機構(1)  
**PRESSER BAR LIFTING MECHANISM(1)**

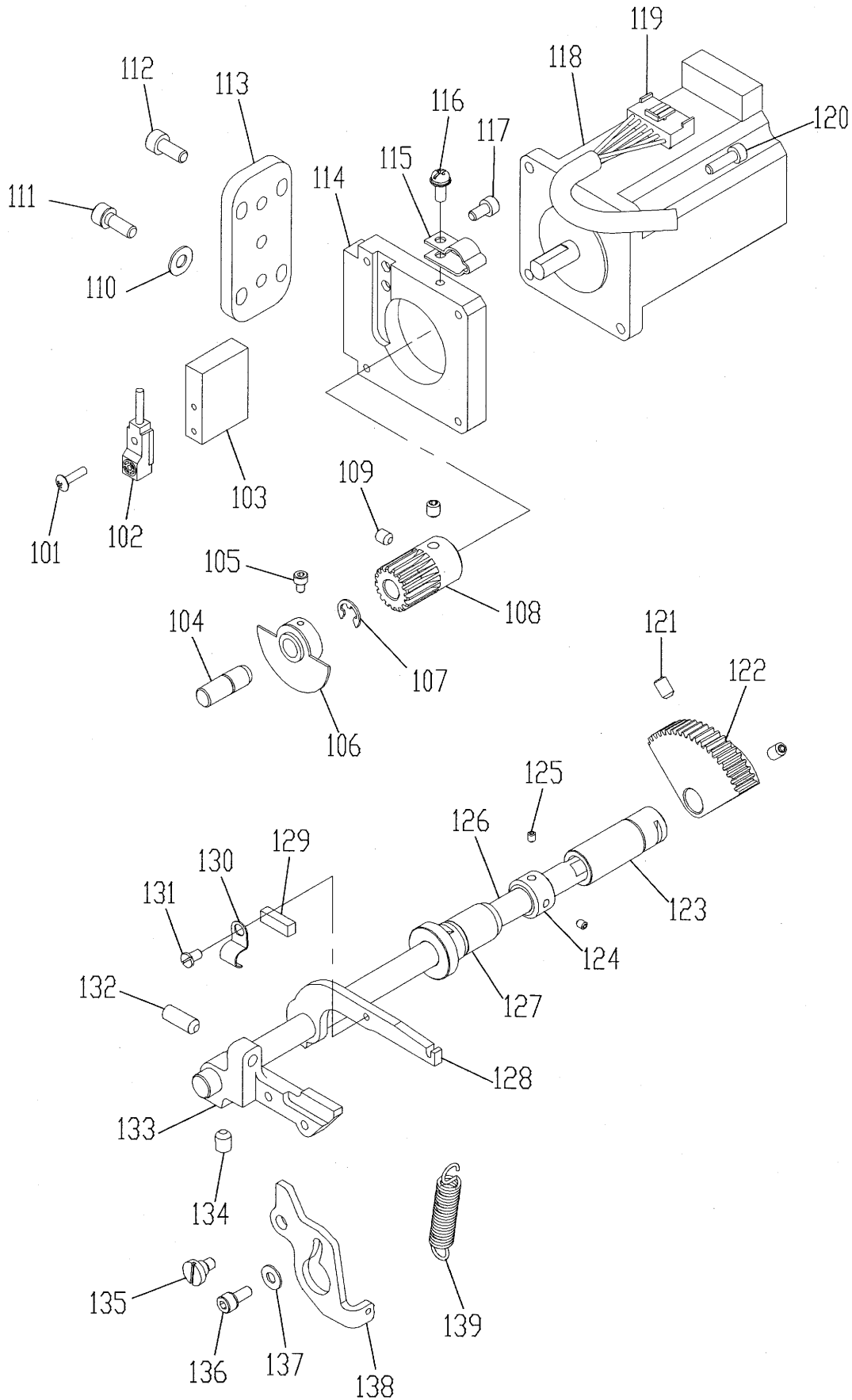

[G] 中押え機構(1)

PRESSER BAR LIFTING MECHANISM

Fig no.	変更 Mod.	部品コード Parts no.	品名	Description	数量 Amt. Req.
G 101		M90301036	ボラスネジ M3X12	Screw M3X12	1
G 102		MH27E0484	キンセツスイッチ	Detector	1
G 103		MH27A0603	センサトリツケダイ	Detector bracket	1
G 104		MH27A3454	ジク	Shaft	1
G 105		M93003021	ロッカクアナツキホルト M3X6	Screw M3X6	1
G 106		MH27A0407	ケンシュツハン	Detector plate	1
G 107		M90511065	Eカ`外メウ 6	E-type retaining ring 6	1
G 108		MH10A2722	ヒラハゲルマ	Gear	1
G 109		M94001001	ユルミホ`ウシツキトメネジ` M5X6	Screw M5X6	2
G 110		M90511050	ミガ`キサ`カ`ネ 5	Washer 5	4
G 111		M95014017	セフテイソケット M5X14	Safety socket bolt M5X14	4
G 112		M95003021	ロッカクアナツキホルト M5X12	Socket bolt M5X12	3
G 113		MH27A0850	モ-タ`イ`トリツケイタ`	Presser foot motor adapter	1
G 114		MH27A1603	ナカオサエモ-タ`トリツケダイ`	Presser foot motor bracket	1
G 115		MB60A0620	ナイロンクリップ` FGC-8	Nylon clip FGC-8	1
G 116		K14S90203410	SW-PW Pナ`ヘ`ネジ` M4X10	Screw M4X10	1
G 117		M95018021	ロッカクアナツキホルト M4X8	Socket bolt M4X8	2
G 118		MH10A1848	ステッピ`ングモ-タ`	Stepping motor	1
G 119		MH27A0508	ケ-ブル (PFモ-タ`)	Cable (PF motor)	1
G 120		M94040021	ロッカクアナツキホルト M4X14	Socket bolt M4X14	4
G 121		M95004020	ロッカクアナツキトメネジ` M5X8	Screw M5X8	2
G 122		MH10A1683	オウキ`ハゲルマ	Sector gear	1
G 123		MH27A1833	ナカオサエメタル (ウシロ)	Presser foot bushing (rear)	1
G 124		MH10A1352	セツカラー	Set collar	1
G 125		M91055020	ロッカクアナツキトメネジ` M4X4	Screw M4X4	2
G 126		MH27A0390	ナカオサエ`ク`ウシク`	Presser foot driving shaft	1
G 127		MH27A2833	ナカオサエメタル (マエ) クミタテ`	Presser foot bushing (front) assy	1
G 128		MH10A1252	ナカオサエアケレバ- B	Presser foot lifting lever B	1
G 129		MH10A1740	フェルト	Felt	1
G 130		MN70A1780	ホルダ`	Holder	1
G 131		M90908003	マルヒラネジ` 9/64(40)X6	Screw 9/64(40)X6	1
G 132		M91651020	ロッカクアナツキトメネジ` M6X16	Screw M6X16	1
G 133		MH10A0252	ナカオサエアケレバ- A	Presser foot lifting lever A	1
G 134		M91650020	ロッカクアナツキトメネジ` M6X8	Screw M6X6	1
G 135		M91127015	ヒラネジ`ダンツキ 11/64(40)X5	Screw 11/64(40)X5	1
G 136		M94001017	セフテイソケット M4X10	Safety socket bolt M4X10	1
G 137		M90421050	ミガ`キサ`カ`ネ 4	Washer 4	1
G 138		MH10A2708	ハ`ネカケ`	Hook plate	1
G 139		MH10A4572	ツルマキハ`ネ`	Spring	1

**H** 中押え機構(2)  
**PRESSER BAR LIFTING MECHANISM(2)**

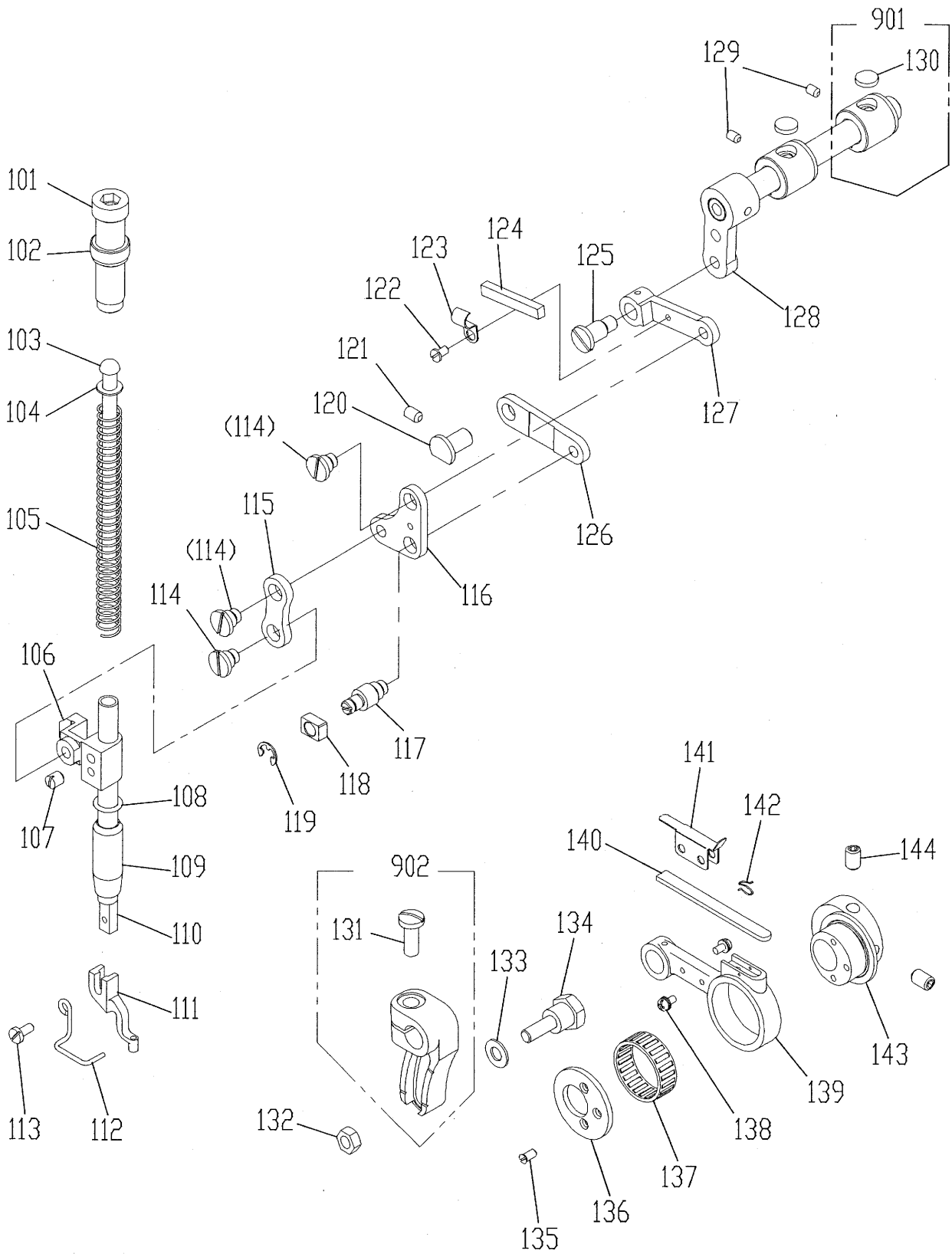



## [H] 中押え機構(2)

## PRESSER BAR LIFTING MECHANISM

Fig no.	変更 Mod.	部品コード Parts no.	品名	Description	数量 Amt. Req.
H 101		M93220035	ツマミネジ 1/2(28)X43	Thumb screw 1/2(28)X43	1
H 102		M93202047	ナット 1/2(28)	Nut 1/2(28)	1
H 103		MS03A0703	アンナイボウ	Presser bar guide	1
H 104		M90632050	ワザガネ 6	Washer 6	1
H 105		MS03A1572	ツルマキバネ	Spring	1
H 106		MG75A0265	オサエホウダキ	Presser bar holder	1
H 107		M91506001	トメネジ 15/64(28)X7	Screw 15/64(28)X7	1
H 108		M90600085	リング	O-ring	1
H 109		MH10A0267	オサエホウメタル	Presser bar bushing	1
H 110		MS03A0262	オサエホウ	Presser bar	1
H 111		MA21A0256	ナカオサエ φ2.5	Presser foot φ2.5	1
H 112		MH10A0626	ニードルガード	Needle guard	1
H 113		M90922002	ヒラネジ 9/64(40)X8	Screw 9/64(40)X8	1
H 114		M91690015	ヒラネジダンツキ 1/4(40)X4	Screw 1/4(40)X4	3
H 115		MH10A5910	リンク	Link	1
H 116		MH10A0763	ベルクランク	Bell crank	1
H 117		M91553015	ダンツキネジ 1/4(40)X4	Screw 1/4(40)X4	1
H 118		MF10A0325	カクコマ	Square block	1
H 119		M90505065	Eガ外メワ 5	E-type retaining ring 5	1
H 120		MH10A0283	ツバツキジク	Stepped pin	1
H 121		M95004020	ロッカクアナツキトメネジ M5X8	Screw M5X8	1
H 122		M90908003	マルヒラネジ 9/64(40)X6	Screw 9/64(40)X6	1
H 123		MN70A1780	ホルダ	Holder	1
H 124		MG30A0740	フェルト	Felt	1
H 125		M91691015	ヒラネジダンツキ 1/4(40)X7	Screw 1/4(40)X7	1
H 126		ME10A7910	リンク	Link	1
H 127		MH10A1956	レンセツカン	Link	1
H 128		MH27A0228	ウデクミタテ	Arm shaft assy	1
H 129		M91058020	ロッカクアナツキトメネジ M4X10	Screw M4X10	2
H 130		MS10A1740	フェルト	Felt	2
H 131		M91603003	マルヒラネジ 1/4(24)X16	Screw 1/4(24)X16	1
H 132		M91572045	Uナット M6X0.75	U-nut M6X0.75	1
H 133		M90631050	ミガキワザガネ 6	Washer 6	1
H 134		M96011017	ダンツキボルト M6	Bolt M6	1
H 135		M90902011	マルヒラネジ 9/64(40)X7	Screw 9/64(40)X7	3
H 136		M98016050	ワザガネ	Washer	1
H 137		MN35A0628	ニードルベアリング	Needle bearing	1
H 138		M90859004	SW-PWプライマインネジ M3X6	Screw M3X6	2
H 139		MH10A2956	レンセツカン	Link	1
H 140		MH10A2740	フェルト	Felt	1
H 141		MH10A1741	フェルトオサエ	Felt holder	1
H 142		MF60A0700	センサイクバネ	Spring	1
H 143		MH10A0760	ヘンシンリン	Eccentric cam	1
H 144		M91602020	ロッカクアナツキトメネジ 1/4(40)X10	Screw 1/4(40)X10	2
H 901		MH10E0285	ジョウブジョウゲメタルクミタテ	Bushing assy	2
H 902		MS02A0463	ウデ(ミキ)	Arm (right)	1

**J** 糸切り機構  
**THREAD TRIMMER MECHANISM**

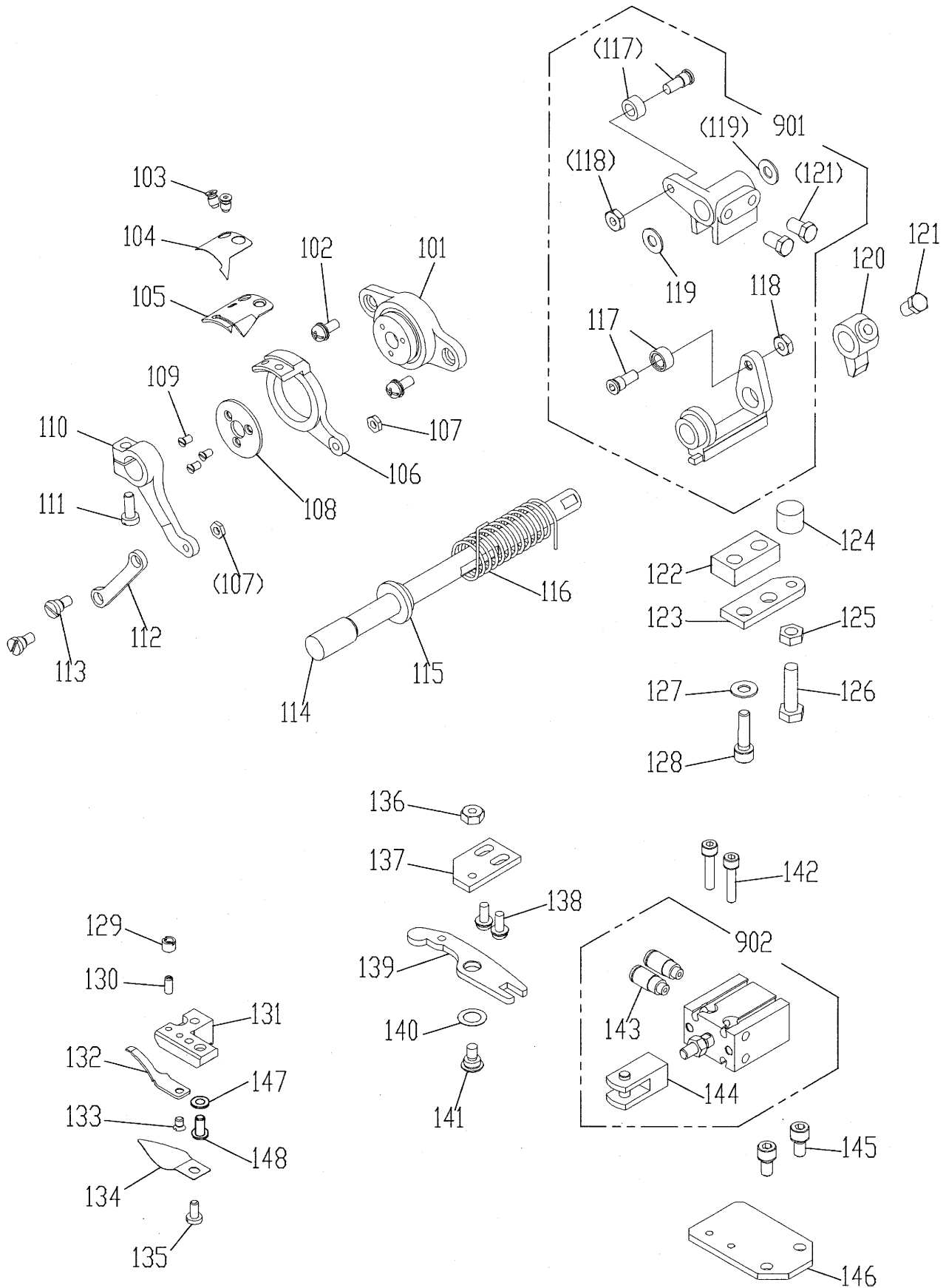

## [J]系切り機構

## THREAD TRIMMING MECHANISM

Fig no.	変更 Mod.	部品コード Parts no.	品名	Description	数量 Amt. Req.
J 101		MF00A1527	ダイザ	Knife holding bracket saddle	1
J 102		M91013004	SW-MWブライナヘネジ M4X10	Screw M4X10	3
J 103		M91151010	サラネジ 11/64(40)X7	Screw 11/64(40)X7	2
J 104		MF02A0834	メス (ヒダリ)	Movable knife (left)	1
J 105		MS07A0782	ホゴイタ	Guard plate	1
J 106		MS07A0836	メスタイ (ヒダリ)	Knife base (left)	1
J 107		M91107045	ナット 11/64(40)	Nut 11/64(40)	2
J 108		M94006052	サガネ	Washer	1
J 109		M90803010	サラネジ 1/8(44)X6	Screw 1/8(44)X6	3
J 110		MF00A1392	外ウウテ	Knife driving crank	1
J 111		M91117002	マルヒラネジ 11/64(40)X11.4	Screw 11/64(40)X11.4	1
J 112		MF00A8910	リンク	Link	1
J 113		M91111015	ヒラネジダンツキ 11/64(40)X6.2	Screw 11/64(40)X6.2	2
J 114		MA25A0891	メスコウトウシク	Knife driving shaft	1
J 115		MF00A0750	ブッシュ	Bushing	1
J 116		MA25A0572	ツルマキハネ	Spring	1
J 117		MF01E0411	コロ・コロジクミタテ	Cam follower, Shoulder screw assy	2
J 118		M91201045	ナット 3/16(28)	Nut 3/16(28)	2
J 119		M71018050	サガネ(ゴムワ)	Washer	2
J 120		MH50A3477	ストッパ	Stopper	1
J 121		M91501022	ボルト 15/64(28)X10	Bolt 15/64(28)X10	3
J 122		MH50A2476	スパーサ	Spacer	1
J 123		MF00A1477	ストッパイタ	Stopper plate	1
J 124		MH50A0416	ストッパゴム	Stopper	1
J 125		M91502045	ナット 15/64(28)	Nut 15/64(28)	1
J 126		M91512022	ボルト 15/64(28)X20	Bolt 15/64(28)X20	1
J 127		M90511050	ミカキサガネ 5	Washer 5	2
J 128		M95001017	セフテイソケット M5X20	Safety socket bolt M5X20	2
J 129		M91110045	ナット 9/64(40)	Nut 9/64(40)	1
J 130		M90913001	トメネジ 9/64(40)X8.5	Screw 9/64(40)X8.5	1
J 131		MF00A1603	トリツケダイ	Bracket for fixed blade	1
J 132		MS10A0838	コテイメス	Fixed blade	1
J 133		M90907010	サラネジ 9/64(40)X5	Screw 9/64(40)X5	1
J 134		MS07A0180	イトアンナイ	Thread guide	1
J 135		M90921002	ヒラネジ 9/64(40)X8	Screw 9/64(40)X8	1
J 136		M91202045	ナット 3/16(28)	Nut 3/16(28)	1
J 137		MS07A1603	トリツケイタ	Adapter	1
J 138		M91056004	SW-PWブライナヘネジ M4X10	Screw M4X10	2
J 139		MF00A0391	外ウイタ	Thread trimmer driving lever	1
J 140		ME20A0915	シムリング	Washer	1
J 141		M91212015	ヒラネジダンツキ 3/16(28)X6.5	Screw 3/16(28)X6.5	1
J 142		M94024017	セフテイソケット M4X20	Safety socket bolt M4X20	2
J 143		MA20A5571	ワシタツツキテ	Connector	2
J 144		MA16A0621	ナックル	Knuckle	1
J 145		M95002017	セフテイソケット M5X12	Safety socket bolt M5X12	2
J 146		MH27A1601	シリンダトリツケイタ	Cylinder bracket	1
J 147		M90422050	コサガネ4	Washer	1
J 148		M91054004	ブライナヘネジ M4X8	Screw M4X8	1
J 901		MB25E0351	カムツイジユウウテクミタテ	Cam follower crank assy	1
J 902		MB61E0434	エアシリンダクミタテ	Air syliner assy	1

**K X-Yテーブル機構(1)**  
**X-Y TABLE MECHANISM(1)**

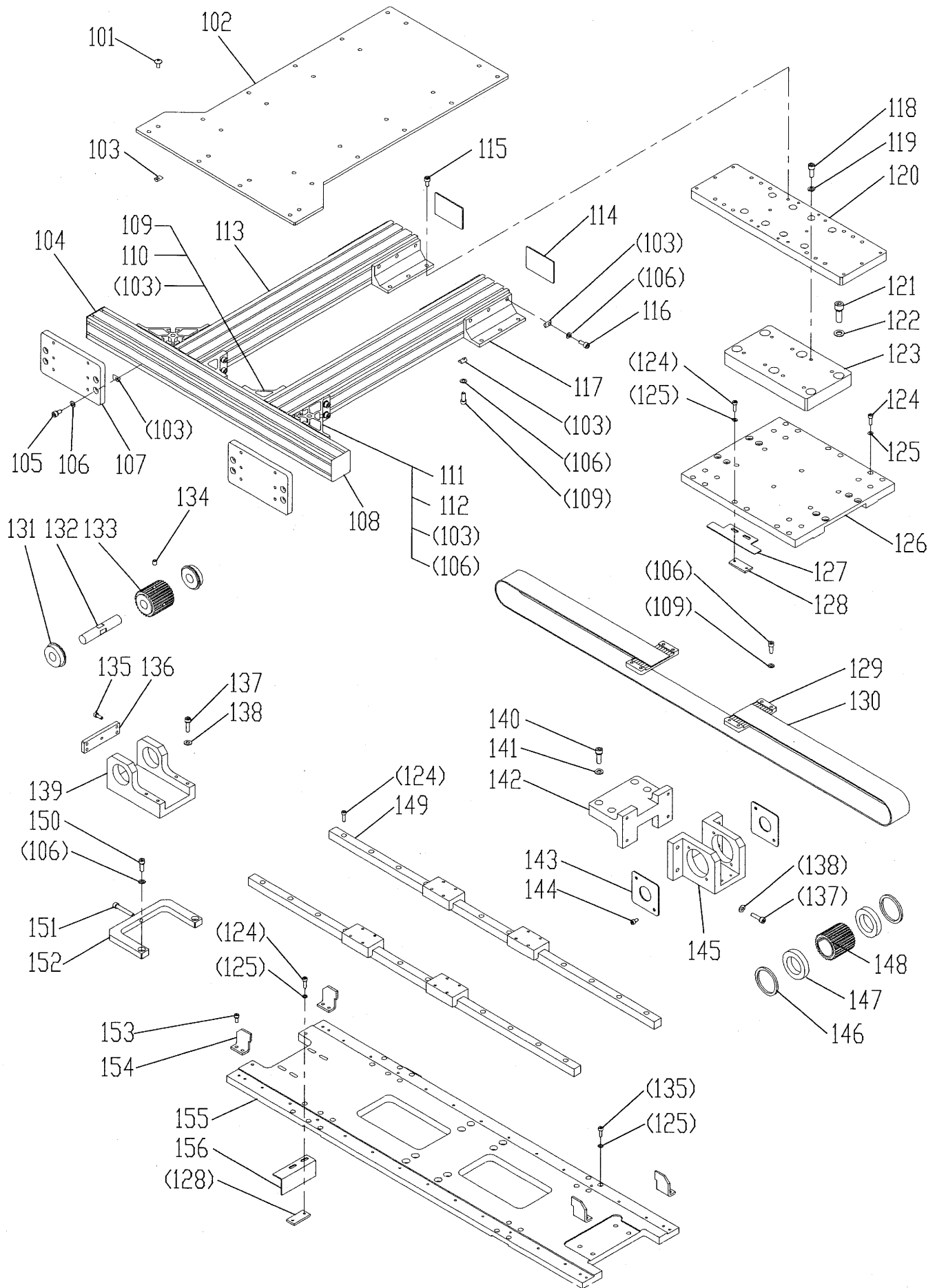

[K] X-Yテーブル機構(1)  
X-Y TABLE MECHANISM(1)

Fig no.	変更 Mod.	部品コード Parts no.	品 名	Description	数量 Amt. Req.
K 101		M90503036	トラスネジ M5X10	Screw M5X10	28
K 102		MH50A0799	ホキョウイタ	Stiffening plate	1
K 103		M95002047	Tナット M5	T-nut M5	76
K 104		MH50A0228	アルミフレーム 40X40	Aluminium frame 40X40	1
K 105		M95002017	セフティソケット M5X12	Safety socket bolt M5X12	8
K 106		M90512050	コザガネ 5	Washer 5	50
K 107		MH50A7601	チャッキングトリツケイタ	Chucking support	2
K 108		MH50A0366	エンドキャップ	End cap	2
K 109		M95014017	セフティソケット M5X14	Safety socket bolt M5X14	28
K 110		MH50A1571	コーナージョイント	Corner joint	2
K 111		M95005017	セフティソケット M5X10	Safety socket bolt M5X10	8
K 112		MH50A2571	コーナージョイント	Corner joint	2
K 113		MH50A1603	アルミフレーム 60X40	Aluminium frame 60X40	2
K 114		MH50A1366	エンドキャップ	End cap	2
K 115		M95002021	ロッカクアナツキボルト M5X10	Socket bolt M5X10	12
K 116		M95003021	ロッカクアナツキボルト M5X12	Socket bolt M5X12	12
K 117		MH50A4758	ブラケット	Bracket	4
K 118		M91651020	ロッカクアナツキボルト M6X16	Socket bolt M6X16	8
K 119		M90632050	コザガネ 6	Washer 6	8
K 120		MH50A8601	アルミフレームトリツケイタ	Aluminium frame support	1
K 121		M98001017	セフティソケット M8X25	Safety socket bolt M8X25	6
K 122		M90825050	コザガネ 8	Washer 8	6
K 123		MH50A5758	ブラケット	Bracket	1
K 124		M94040021	ロッカクアナツキボルト M4X14	Socket bolt M4X14	44
K 125		M90422050	コザガネ 4	Washer 4	36
K 126		MH50A0957	Xジクイドウレース	Movable race X	1
K 127		MH50A1407	Xケンシュツパン	Detector plate X	1
K 128		MH50A0639	ネジイタ	Nut plate	2
K 129		MH50A0778	ベルトオサエ	Belt clamp	2
K 130		MH50A2767	タイミングベルト	Cog belt	1
K 131		MH50A0456	ベアリング	Ball bearing	2
K 132		MH50A4454	ジク	Shaft	1
K 133		MH50A1682	タイミングプーリ	Cog pulley	1
K 134		M96001001	ユルミホウシツキトメネジ M6X8	Screw M6X8	2
K 135		M94007017	セフティソケット M4X12	Safety socket bolt M4X12	20
K 136		MH50A1639	ネジイタ	Plate	1
K 137		M95001017	セフティソケット M5X20	Safety socket bolt M5X20	8
K 138		M90511050	ミガキザガネ 5	Washer 5	8
K 139		MH50A6758	ブラケット X (ジュウトウ)	Bracket	1
K 140		M96004017	セフティソケット M6X20	Safety socket bolt M6X20	4
K 141		M90631050	ミガキザガネ 6	Washer 6	4
K 142		MH50A7758	ブラケット	Bracket	1
K 143		MH50A0771	ベアリングオサエ	Bearing cover	2
K 144		M94002017	セフティソケット M4X8	Safety socket bolt M4X8	4
K 145		MH50A8758	ブラケット X (クトウ)	Bracket	1
K 146		MH50A0476	スペーサ	Spacer	2
K 147		MH50A1456	ベアリング	Bearing	2
K 148		MH50A1767	タイミングプーリ	Cog pulley	1
K 149		MH50A1920	スライドガイド X	Slide guide X	2
K 150		M95004017	セフティソケット M5X16	Safety socket bolt M5X16	2
K 151		M95008021	ロッカクアナツキボルト M5X35	Socket bolt M5X35	1
K 152		MH50A0527	テンショナー	Tensioner	1
K 153		M94001017	セフティソケット M4X10	Safety socket bolt M4X10	8
K 154		MH50A2477	ストップ X	Stopper X	4
K 155		MH50A1957	Yジクイドウレース	Movable race Y	1
K 156		MH50A1407	Yケンシュツパン	Detector plate Y	1

**L X-Yテーブル機構(2)**  
**X-Y TABLE MECHANISM(2)**

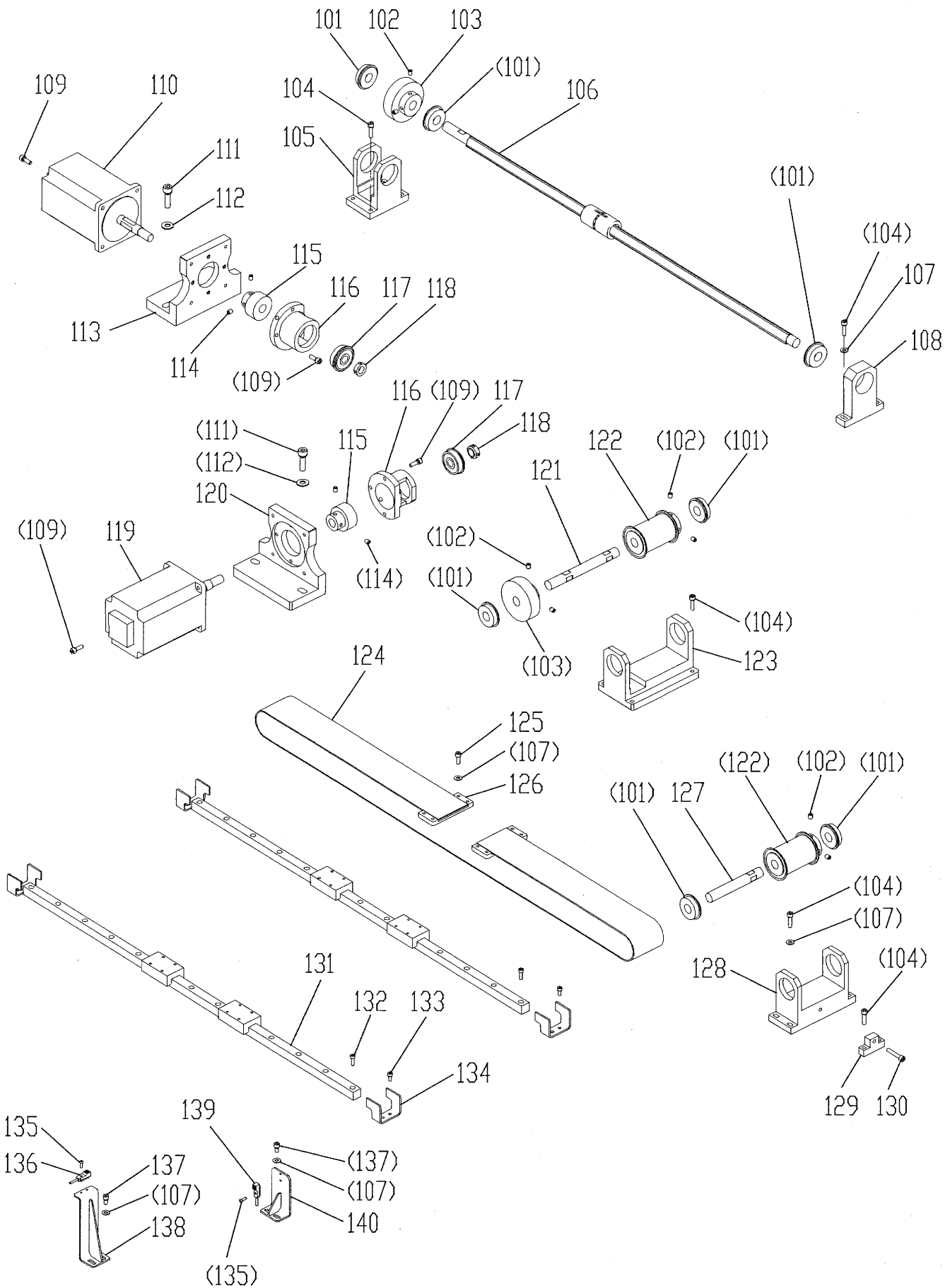

[L]X-Yテーブル機構(2)  
X-Y TABLE MECHANISM(2)

Fig no.	変更 Mod.	部品コード Parts no.	品名	Description	数量 Amt. Req.
L 101		MH50A2456	ベアリング	Ball bearing	7
L 102		M96001001	ユルミホウシツキトメネジ M6X8	Screw M6X8	8
L 103		MH50A0683	ヒラハグルマダイ	Spur gear	2
L 104		M95001017	セフティソケット M5X20	Safty socket bolt M5X20	16
L 105		MH50A9758	キアブラケット	Bracket	1
L 106		MH50A3454	ボールスプライン	Ball sprine	1
L 107		M90511050	ミガキサガネ 5	Washer 5	18
L 108		MH50B0758	ベアリングブラケット	Bracket	1
L 109		M95004017	セフティソケット M5X16	Safty socket bolt M5X16	14
L 110		MH50E0849	ステッピングモータクミタテ X	Motor complete X	1
L 111		M98002017	セフティソケット M8X30	Safty socket bolt M8X30	4
L 112		M90823050	ミガキサガネ 8	Washer 8	4
L 113		MH50B1758	モータブラケット	Motor bracket	1
L 114		M96002001	ユルミホウシツキトメネジ M6X6	Screw M6X6	4
L 115		MH50B2722	ヒラハグルマショウ	Spur gear	2
L 116		MH50B3758	ベアリングブラケット	Bearing bracket	2
L 117		MH50A3456	ベアリング	Ball bearing	2
L 118		MH50A0352	セットカラー	Set collar	2
L 119		MH50E1849	ステッピングモータクミタテ Y	Motor complete Y	1
L 120		MH50B4758	モータブラケット	Motor bracket	1
L 121		MH50A1390	Y 外ウジク	Drive shaft Y	1
L 122		MH50A2682	タイミングプーリ	Cog pulley	2
L 123		MH50B5758	プーリキアブラケット	Bracket	1
L 124		MH50A2523	タイミングベルト	Cog belt	1
L 125		M95014017	セフティソケット M5X14	Safty socket bolt M5X14	8
L 126		MH50A1778	ベルトオサエ	Belt clamber	2
L 127		MH50A2454	ジュウトウジク	Shaft	1
L 128		MH50B6758	プーリブラケット	Bracket	1
L 129		MH50B7758	テンションブラケット	Tension bracket	1
L 130		M95006021	ロッカクアナツキホルト M5X30	Socket bolt M5X30	1
L 131		MH50A2920	スライドガイド Y	Slide guide Y	2
L 132		M94040021	ロッカクアナツキホルト M4X14	Socket bolt M4X14	26
L 133		M94001017	セフティソケット M4X10	Safty socket bolt M4X10	8
L 134		MH50A1477	ストップ Y	Stopper Y	4
L 135		M91606022	ロッカクアナツキホルタンホルト M3X10	Screw M3X10	2
L 136		MH50A0484	キンセツスイッチ	Detector	1
L 137		M95005017	セフティソケット M5X10	Safty socket bolt M5X10	4
L 138		MH50A0408	ケンシュツダイ	Detector bracket	1
L 139		MH50A1484	キンセツスイッチ	Detector	1
L 140		MH50A1408	ケンシュツダイ	Detector bracket	1

**M** ワイパー機構  
**WIPER MECHANISM**

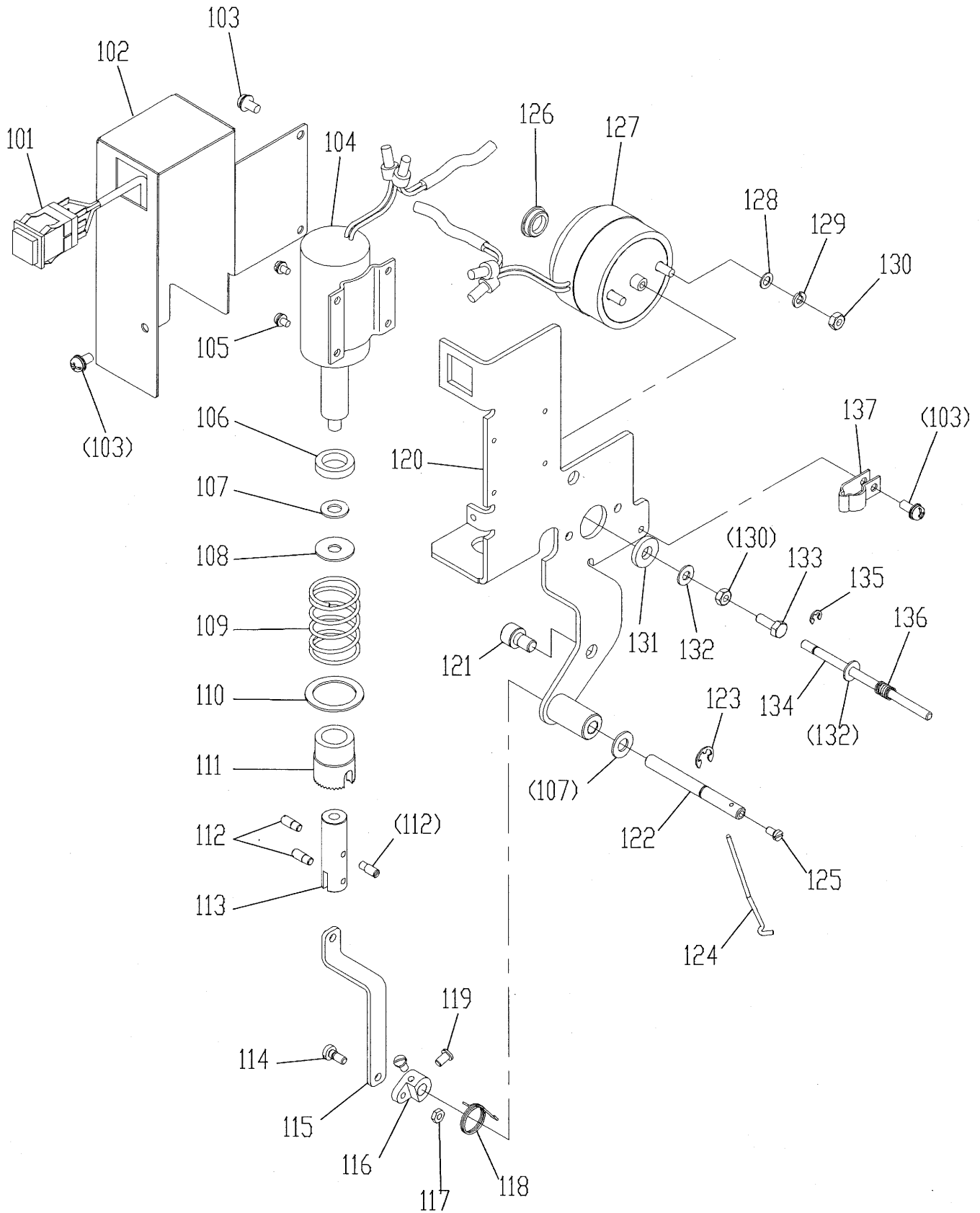



[M]ワイパー機構  
WIPER MECHANISM

Fig no.	変更 Mod.	部品コード Parts no.	品名	Description	数量 Amt. Req.
M 101		MH10A0484	オシホ <sup>°</sup> タンスイッチ <sup>°</sup> クミ	Stop switch assy	1
M 102		MH50A2339	カバー	Cover	1
M 103		M91054004	SW-PW <sup>°</sup> プライナ <sup>°</sup> ネジ M4X8	Screw M4X8	4
M 104		MH10E2519	ワイパ <sup>°</sup> ソレノイド <sup>°</sup> クミ	Wiper solenoid assy	1
M 105		M91334004	SW-PW <sup>°</sup> プライナ <sup>°</sup> ネジ M3X5	Screw M3X5	4
M 106		MH50A0417	ゴムワ	Rubber cushion	2
M 107		M90631050	ミガキサ <sup>°</sup> ガネ 6	Washer 6	2
M 108		M90634050	サ <sup>°</sup> ガネ	Washer	1
M 109		MH10A0700	ハ <sup>°</sup> ネ	Spring	1
M 110		MH10A0915	リング	Ring	1
M 111		MH10A5477	ストッパ <sup>°</sup>	Stopper	1
M 112		M90910033	ピンネジ 9/64(40)X4	Screw 9/64(40)X4	3
M 113		MH10A0571	ツキ <sup>°</sup> テ	Connector	1
M 114		M90932015	ヒラネジ <sup>°</sup> ダンツキ 9/64(40)X9	Screw 9/64(40)X9	1
M 115		MH50A0910	リンク	Thread wiper connecting rod	1
M 116		MH10A0981	ワイパ <sup>°</sup> ウテ	Wiper adapter	1
M 117		M90901045	ナット 9/64(40)	Nut 9/64(40)	1
M 118		MH10A0729	ヒネリハ <sup>°</sup> ネ	Spring	1
M 119		M90908003	マルヒラネジ 9/64(40)X6	Screw 9/64(40)X6	2
M 120		MH50A0982	ワイパ <sup>°</sup> ートリツケイタ	Wiper setting plate	1
M 121		M96002017	セフティソケット M6X12	Safety socket bolt M6X12	2
M 122		MH10A1530	ワイパ <sup>°</sup> ージク	Wiper shaft	1
M 123		M90505065	Eガ <sup>°</sup> 外メ <sup>°</sup> 5	E-type retaining ring 5	1
M 124		MH10A0980	ワイパ <sup>°</sup>	Wiper	1
M 125		M90806002	ヒラネジ 1/8(44)X6	Screw 1/8(44)X6	1
M 126		M91305080	ゴムセン φ13	Rubber plug φ13	1
M 127		MH10E3519	イト <sup>°</sup> ルメソレノイド <sup>°</sup> クミ	Thread release solenoid assy	1
M 128		M90422050	コサ <sup>°</sup> ガネ 4	Washer 4	2
M 129		M90424053	ハ <sup>°</sup> ネサ <sup>°</sup> ガネ 4	Spring washer 4	2
M 130		M91007045	ナット M4	Nut M4	3
M 131		M96010052	サ <sup>°</sup> ガネ	Washer	1
M 132		M90421050	ミガキサ <sup>°</sup> ガネ 4	Washer 4	2
M 133		M91005022	ロツカクホルト M4X12	Hexagon head bolt M4X12	1
M 134		M90434060	ピン	Pin	1
M 135		M90512065	Eガ <sup>°</sup> 外メ <sup>°</sup> 3	E-type retaining ring 3	1
M 136		MH10A2701	ハ <sup>°</sup> ネ	Spring	1
M 137		M94007099	ナイロンクリップ AB-6N	Nylon clip AB-6N	1

**N 給油機構**  
**OIL LUBRICATION MECHANISM**

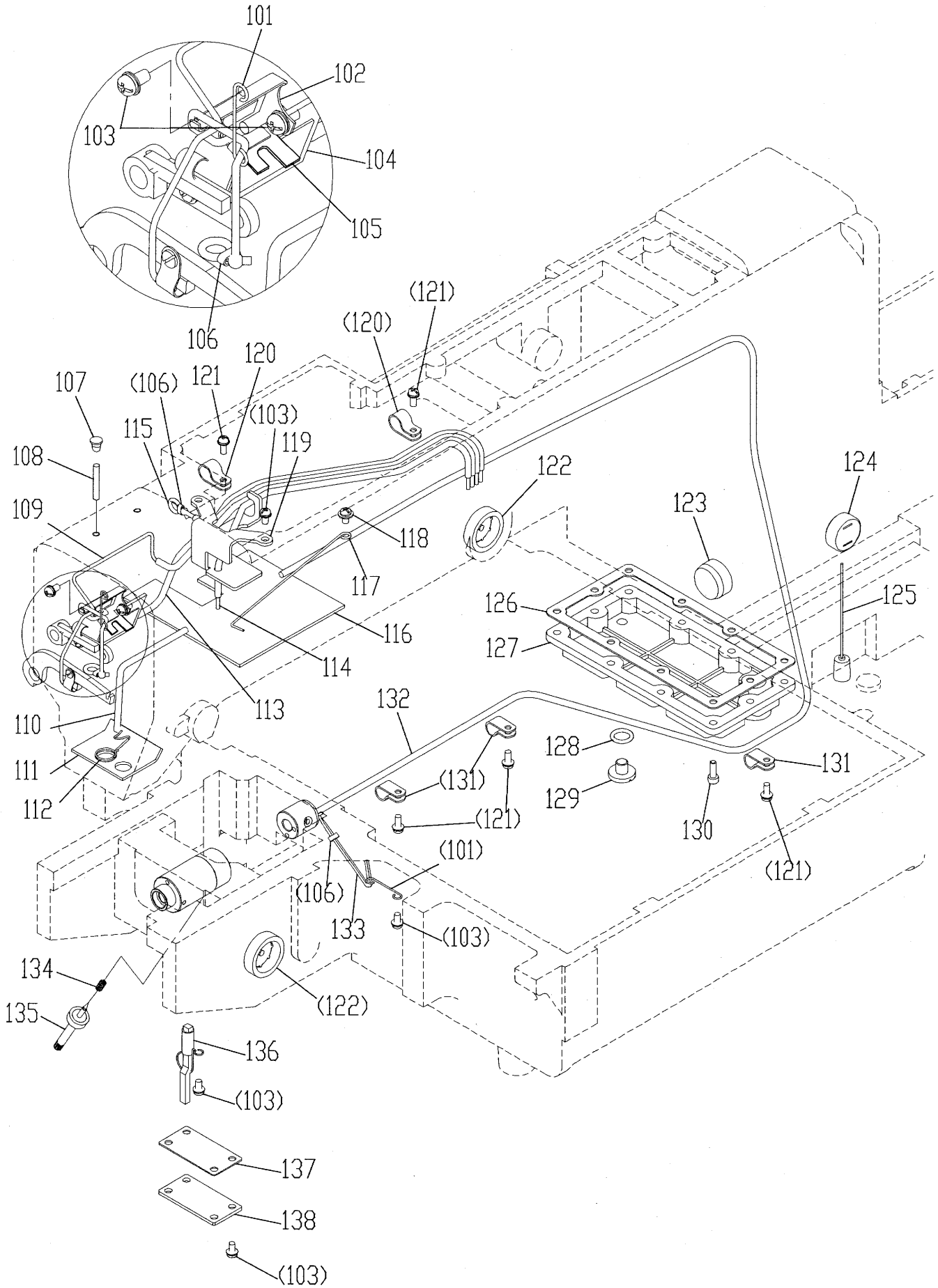

From the library of: Diamond Needle Corp

## [N]給油機構

## OIL LUBRICATION MECHANISM

Fig no.	変更 Mod.	部品コード Parts no.	品名	Description	数量 Amt. Req.
N 101		MS03A2780	ホルダ	Holder	2
N 102		MH27A2780	ホルダ	Holder	1
N 103		M91054004	SW-PW <sup>o</sup> ラマイナ <sup>o</sup> ネジ M4X8	Screw M4X8	11
N 104		MH10A6740	フェルト	Felt	1
N 105		MH25A0740	フェルト	Felt	1
N 106		MF80A0780	ホルダ	Holder	3
N 107		M90573080	ゴムセン φ5.7	Rubber plug φ5.7	2
N 108		MP40A1740	フェルト	Felt	2
N 109		MH27E1688	パイプヒモクミ (ナカオサエ)	Oil pipe assy (presser foot)	1
N 110		MH27E3688	パイプヒモクミ (カンユ)	Oil pipe assy (circulation)	1
N 111		MH10A7740	フェルト	Felt	1
N 112		MF00A2780	ホルダ	Holder	1
N 113		MH27E1148	パイプヒモクミ (ハリホウ)	Oil pipe assy (needle bar)	1
N 114		MH27E0688	パイプヒモクミ (ヘンシンリン)	Oil pipe assy (eccentric cam)	1
N 115		MH27E2688	パイプヒモクミ (ナカオサエメタル)	Oil pipe assy (presser foot bushing)	1
N 116		MH27A0740	フェルト	Felt	1
N 117		MH27A1780	ホルダ	Holder	1
N 118		M91071004	SW-MW <sup>o</sup> ラマイナ <sup>o</sup> ネジ M4X8	Screw M4X8	1
N 119		MH27A0780	ホルダ	Holder	1
N 120		M94007099	ナイロンクリップ AB-6N	Nylon clip AB-6N	2
N 121		M91056004	SW-PW <sup>o</sup> ラマイナ <sup>o</sup> ネジ M4X10	Screw M4X10	5
N 122		MN10A0135	アブラマド	Oil gauge	2
N 123		MH27A0500	ゴムセン φ25	Rubber plug φ25	1
N 124		MF13A0135	アブラマド	Oil gauge	1
N 125		MH27A0225	ウキコクミタテ	Floater	1
N 126		MH27A0691	ソコフタガスケット	Gasket for bottom cover	1
N 127		MH27A0516	ソコフタ	Bottom cover	1
N 128		M91101085	リング	O-ring	1
N 129		M92004002	ヒラネジ 5/16(24)X8	Screw 5/16(24)X8	1
N 130		M94003021	ソケットアナツキボルト M4X12	Socket bolt M4X12	10
N 131		MN60A0620	ナイロンクリップ AB-5N	Nylon clip AB-5N	3
N 132		MH27E4688	パイプヒモクミ (カンユ)	Oil pipe assy (circulation)	1
N 133		MH27A0148	ヒモ	Oil braid	1
N 134		MG30A0700	ツルマキバネ	Spring	1
N 135		M91008035	ユリョウチョウセツネジ	Oil adjusting screw	1
N 136		MH27E5688	パイプフェルトクミタテ	Oil pipe complete	1
N 137		MS10A1691	ガスケット	Gasket	1
N 138		MS10A1742	アブラフタ	Cap	1

**P** 配線配管関係  
**CABLE AND AIR COMPONENTS**

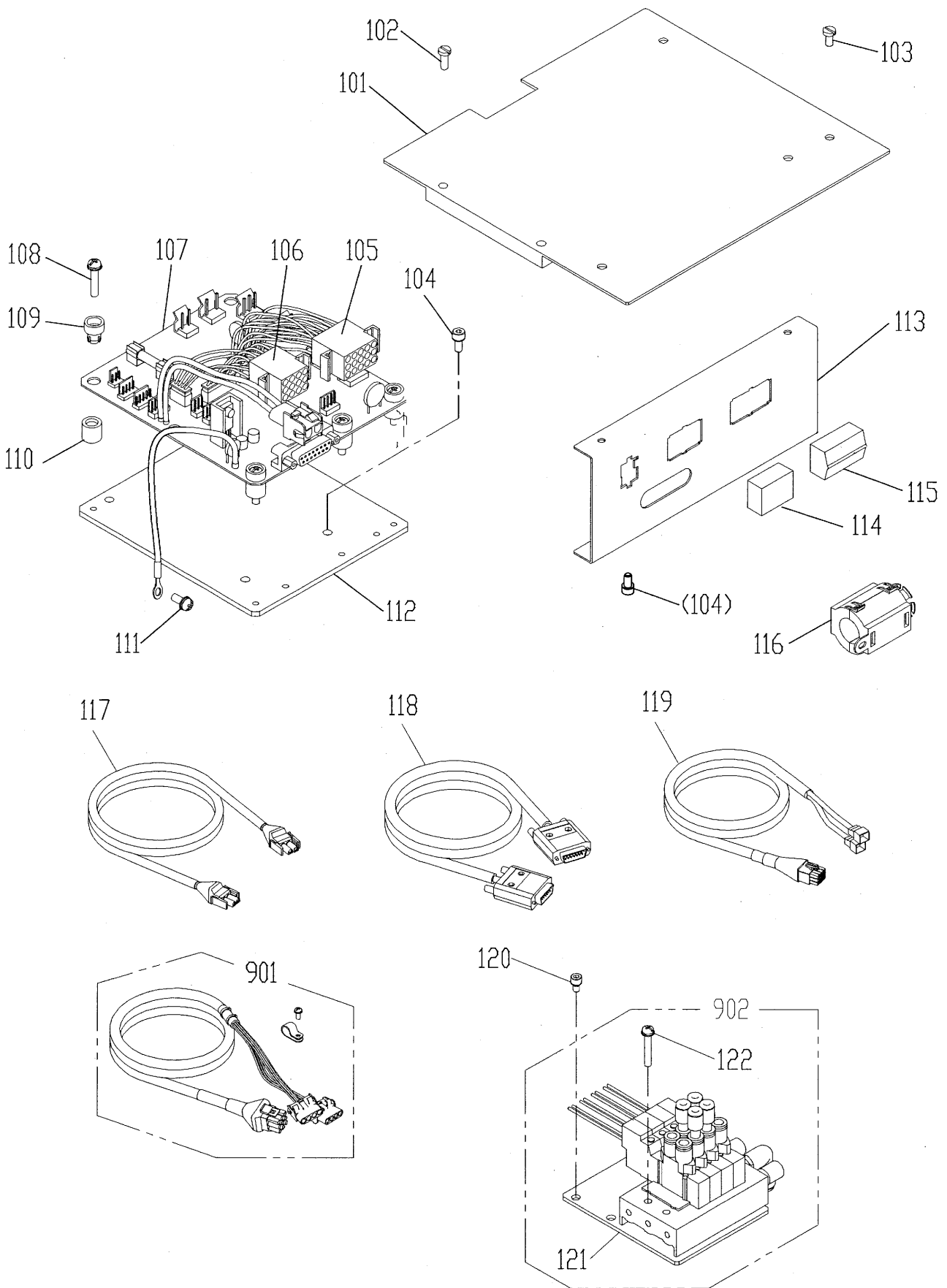

[P]配線・配管関係

CABLE COMPONENT & PNEUMATIC CONTROL UNIT

Fig no.	変更 Mod.	部品コード Parts no.	品名	Description	数量 Amt. Req.
P 101		MH50A3339	パンカバー	Print circuit board cover	1
P 102		M90991002	ヒラネジ M4X12	Screw M4X12	2
P 103		M90990002	ヒラネジ M4X8	Screw M4X8	4
P 104		M94002017	セフティソケット M4X8	Safety socket bolt M4X8	6
P 105		MH10A3508	セツゾクデンセンカミタテ 15P	Connecting cable assy 15P	1
P 106		MH10A4508	セツゾクデンセンカミタテ 12P	Connecting cable assy 12P	1
P 107		M850G2SOL	ソレノイドキバン PLK-G2-SOL	Print circuit board PLK-G2-SOL	1
P 108		M91057004	SW-PW プライナネジ M4X20	Screw M4X20	5
P 109		MB60A0366	ワントッチブッシュ	Nylon bush	5
P 110		MB60A2352	ワントッチブッシュ	Nylon bush	5
P 111		M91056004	SW-PW プナネジ M4X10	Screw M4X10	1
P 112		MH50A5601	キバントリツケイタ	Print circuit board adapter	1
P 113		MH50A6601	コネクタトリツケイタ	Connector panel	1
P 114		MH10B2339	ダスターカバー	Duster cover	1
P 115		MH10B1339	ダスターカバー	Duster cover	1
P 116		K14M19400102	フェライトコア	Ferritic core	1
P 117		M97358099	ケーブル(SOLキバンデンゲン)CEヨウ	Cable(SOL power) for CE	1
P 118		M97320099	ケーブル(SOLキバンシンコウ)	Cable(SOL signal pulse)	1
P 119		MH50A1508	XYエンコーダケーブル	XY encoder cable	1
P 120		M95003017	セフティソケット M5X8	Safety socket bolt M5X8	2
P 121		MH50A0598	デンジベントリツケイタ	Solenoid valve mounting plate	1
P 122		M91066004	SW-PW プライナネジ M4X25	Screw M4X25	4
P 901		MH50A2508	XYモータケーブルセット	XY motor cable set	1
P 902		MH50E1599	デンジベントリツケイタ	Solenoid valve complete	1

Q テーブル関係(1)  
TABLE & STAND

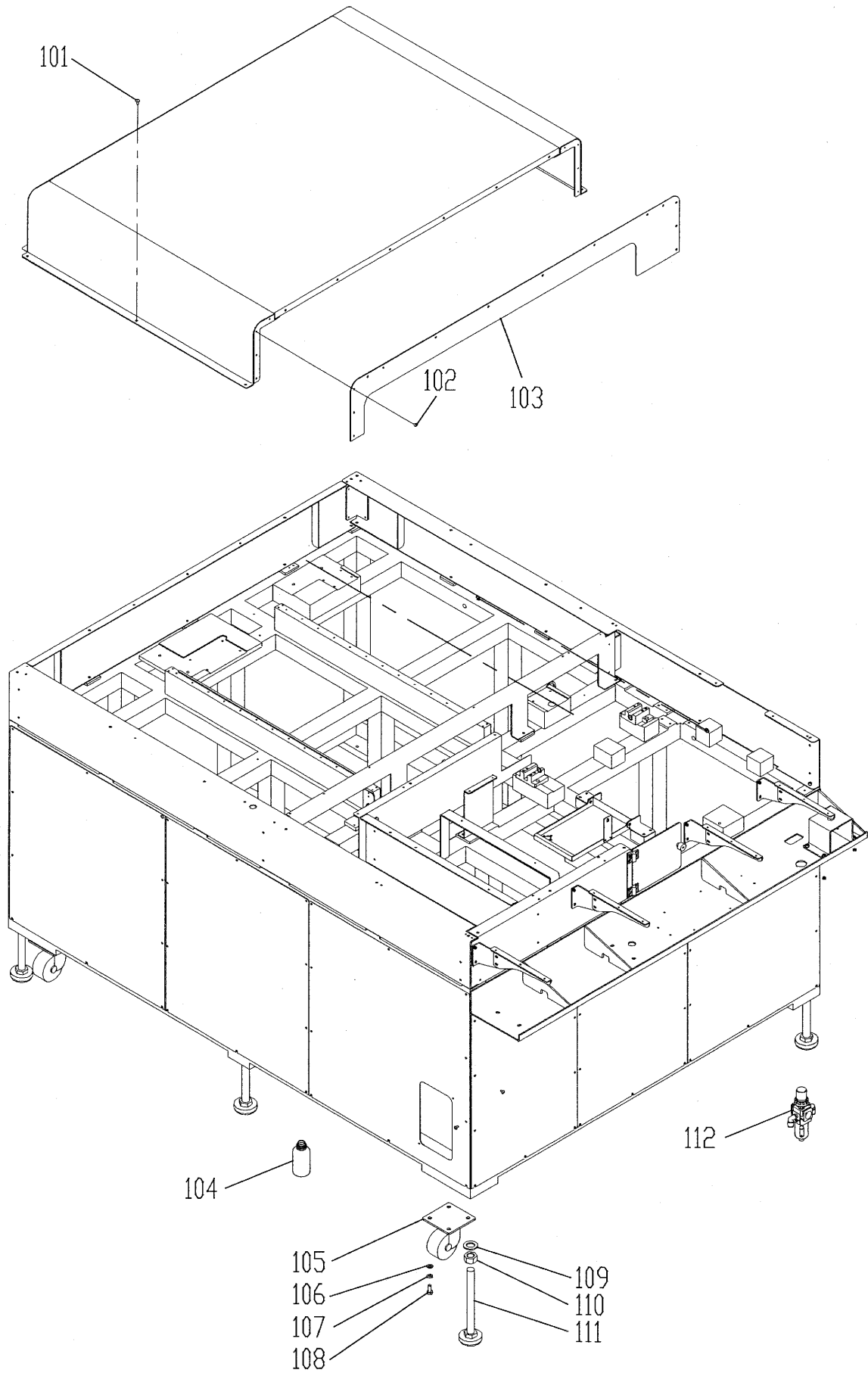

[Q]テーブル関係  
TABLE & STAND

Fig no.	変更 Mod.	部品コード Parts no.	品 名	Description	数量 Amt. Req.
Q 101		M90503036	トラスネジ M5X10	Screw M5X10	10
Q 102		M90403036	トラスネジ M4X8	Screw M4X8	14
Q 103		MH50A0797	ホゴシート	Protection sheet	1
Q 104		MF20A0130	アブラビン	Oil bottle	1
Q 105		MB50A1972	キャスター	Caster	4
Q 106		M90823050	ミガキザカネ 8	Washer 8	16
Q 107		M90803053	ハネザカネ 8	Spring washer 8	16
Q 108		M98021020	ロツカクホルト 8X20	Hexagon bolt	16
Q 109		M92002050	ミガキザカネ 20	Washer 20	6
Q 110		M95021045	ナット M20	Nut M20	6
Q 111		MA30A0166	アジャスターフット	Adjustor	6
Q 112		ME40A0963	フィルタレギュレータ	Filter regulator	1

**R** 付属品(1)  
**ACCESSORIES(1)**

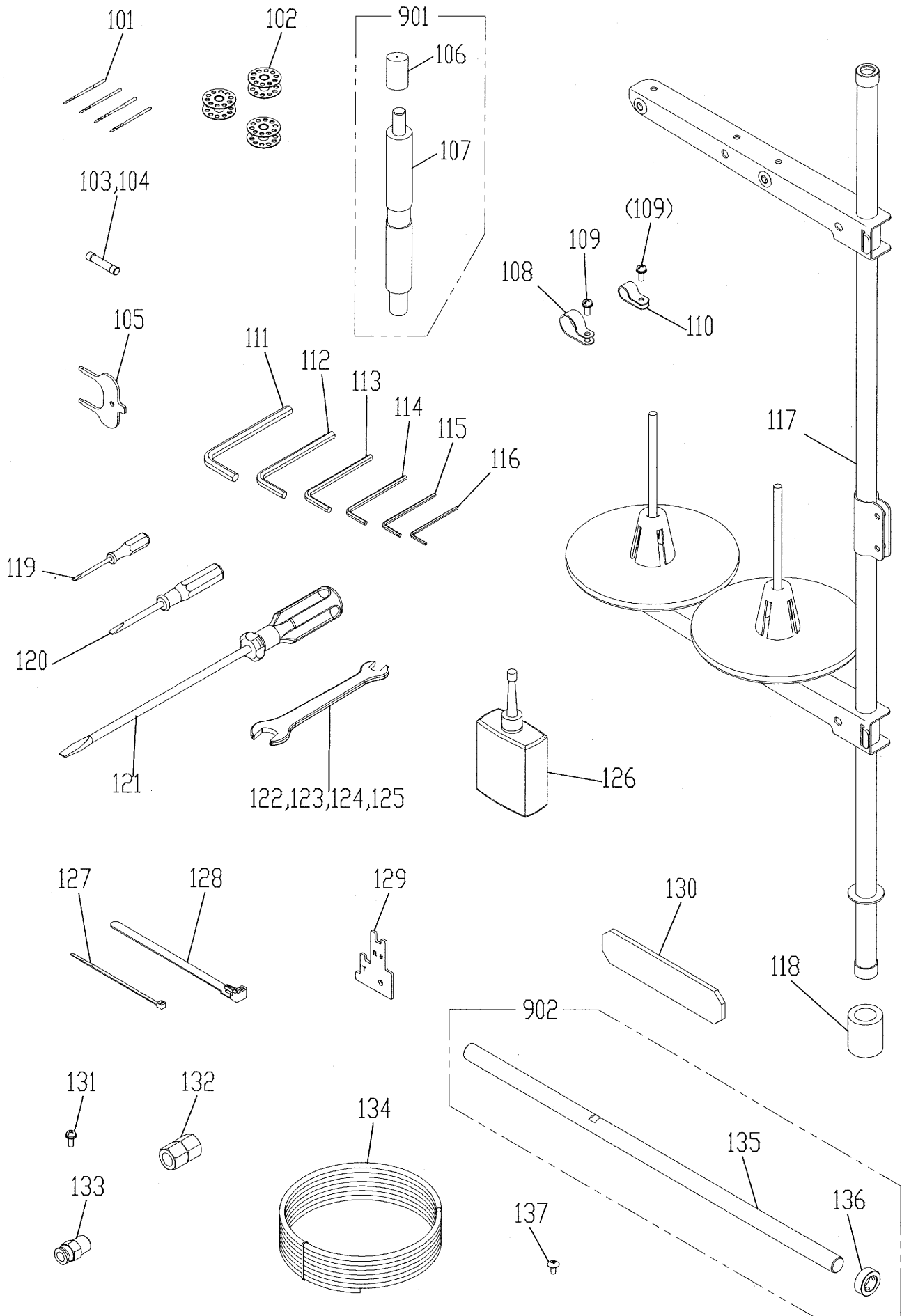



[R] 付属品(1)  
ACCESSORIES(1)

Fig no.	変更 Mod.	部品コード Parts no.	品名	Description	数量 Amt. Req.
R 101		MS02A0128	ミシハリ DPX17#18	Needle DPX17#18	4
R 102		MF25B0123	ホビン	Bobbin	3
R 103		MH10A3FUS	ヒューズ 2.5A	Fuse 2.5A	1
R 104		MH10A2FUS	ヒューズ 20A	Fuse 20A	1
R 105		MF17A0565	カド・チョウセイグ	Speed command disk adjusting plate	1
R 106		MH40A1397	ウレタンクッション	Cushion	1
R 107		MH50A0613	トウブササエ	Head rest	1
R 108		MB60A2620	ナイロンクリップ AB-10N	Nylon clip AB-10N	1
R 109		M91056004	SW-PW プライマインヘネジ M4X10	Screw M4X10	2
R 110		MB60A1620	ナイロンクリップ AB-8N	Nylon clip AB-8N	1
R 111		MS05A1976	ロッカホウレンチ 6	Hexagonal wrench 6	1
R 112		MS05A0976	ロッカホウレンチ 5	Hexagonal wrench 5	1
R 113		MS01A1976	ロッカホウレンチ 4	Hexagonal wrench 4	1
R 114		MS02A2976	ロッカホウレンチ 3	Hexagonal wrench 3	1
R 115		MS02A1976	ロッカホウレンチ 2.5	Hexagonal wrench 2.5	1
R 116		MS02A0976	ロッカホウレンチ 2	Hexagonal wrench 2	1
R 117		MH10E0193	イタテダイクミタテ	Cotton stand assy	1
R 118		MH50A0352	イタテダイカラー	Cotton stand collar	1
R 119		MB02A1608	ドライバー (ショウ)	Screw driver (small)	1
R 120		MF04A0608	ドライバー (チュウ)	Screw driver (middle)	1
R 121		MF00A0608	ドライバー (ダイ)	Screw driver (large)	1
R 122		MS02A0479	スパナ13-17	Spanner 13-17	1
R 123		MM10A1479	スパナ10-14	Spanner 10-14	1
R 124		MS10A1976	スパナ8-9	Spanner 8-9	1
R 125		MS10A2976	スパナ6-7	Spanner 6-7	1
R 126		MF10A0149	アブラサシ	Oiler	1
R 127		MF06A1620	ケツクバンド	Cord tie	1
R 128		MB60A0201	ケツクバンド	Cord tie	3
R 129		MH27A0409	ウワイチゲージ	Up position gauge	1
R 130		MH27A6476	スペーサ	Spacer	1
R 131		M91056004	SW-PW Pナヘネジ M4X10	Screw M4X10	1
R 132		M91010089	ロッカソケット	Socket	1
R 133		MA30A0571	ワンタッチツギテ	Quickjoint	1
R 134		MH50A0567	エアチューブ	Air tube	1
R 135		MH50A0454	シャフト	Shaft	1
R 136		MH50A1352	セットカラー	Set collar	1
R 137		M90403036	トラスネジ M4X8	Screw M4X8	42
R 901		MH50A1613	トウブササエセット	Head rest set	1
R 902		MH50A1454	テントウホジヨバセット	Support bar set	1

**S** 付属品(2)  
ACCESSORIES(2)

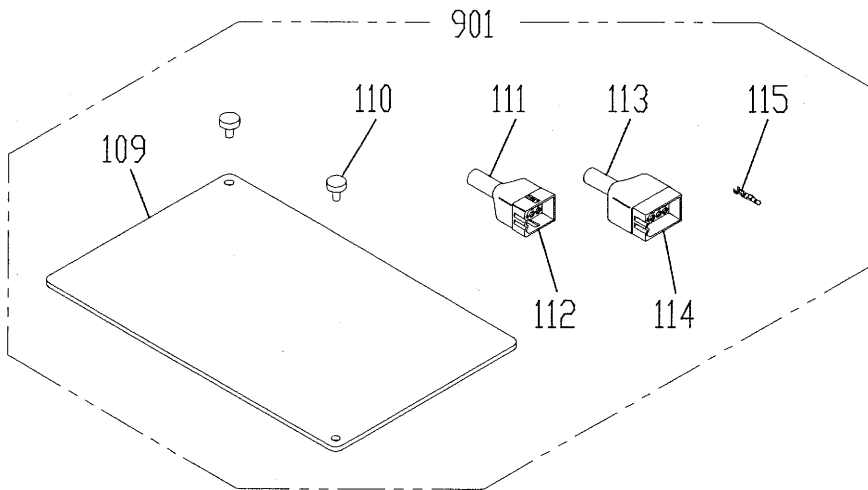
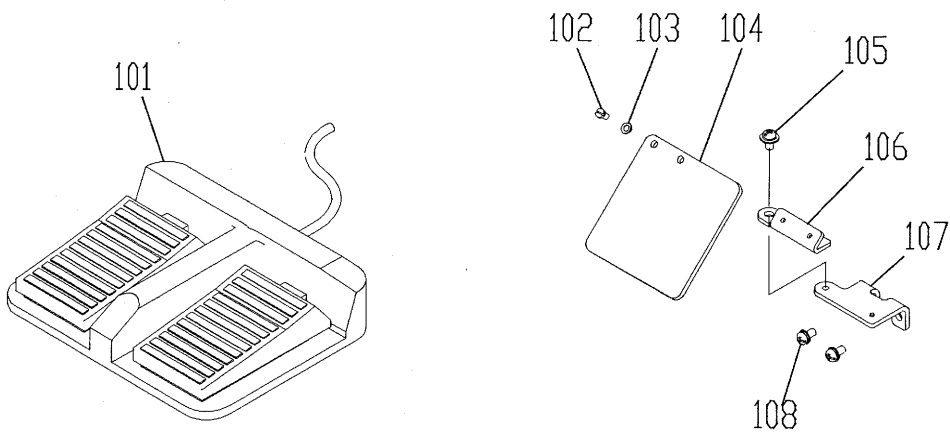

[S]付属品(2)  
ACCESSORIES(2)

Fig no.	変更 Mod.	部品コード Parts no.	品 名	Description	数量 Amt. Req.
S 101		M860A0FSW	フットスイッチ	Foot switch	1
S 102		M90806002	ヒラネジ 1/8(44)X6	Screw 1/8(44)X6	2
S 103		M90317050	ワザガネ 3	Washer 3	2
S 104		MH10A0160	アイガード	Eye guard	1
S 105		M91071004	SW-MWプライナヘネジ M4X8	Screw M4X8	1
S 106		MH10A7601	アイガードトリツケイタ	Eye guard bracket	1
S 107		MH10A8601	トリツケイタ	Mounting plate	1
S 108		M91054004	SW-PWプライナヘネジ M4X8	Screw M4X8	2
S 109		MH50A0742	フタ	Cover	1
S 110		M90404036	ジュシロレットネジ	Screw	2
S 111		K14M94319012	コネクタ 12P	Connector 12P	1
S 112		K14M96821809	ナイロンキャップ 12P	Nylon cap 12P	1
S 113		K14M94319015	コネクタ 15P	Connector 15P	1
S 114		K14M96822602	ナイロンキャップ 15P	Nylon cap 15P	1
S 115		K14M77014710	ターミナル	Terminal	1
S 901		MH50A0749	テーブルフソクヒンセット	Table accessories set	1

索引  
INDEX-1

部品コード Parts No.	ページ Page	Fig No.	部品コード Parts No.	ページ Page	Fig No.	部品コード Parts No.	ページ Page	Fig No.	部品コード Parts No.	ページ Page	Fig No.
K14M19400102	== P27 ==	P 116	M90631050	== P23 ==	M 107	M91055020	== P3 ==	B 141	M91650020	== P9 ==	E 116
K14M77014710	== P33 ==	S 115	M90632050	== P15 ==	H 104	M91056004	== P17 ==	J 138	M91651020	== P13 ==	G 132
K14M94319012	== P33 ==	S 111	↑	== P19 ==	K 119	↑	== P25 ==	N 121	↑	== P19 ==	K 118
K14M94319015	== P33 ==	S 113	M90634050	== P23 ==	M 108	↑	== P27 ==	P 111	M91690015	== P15 ==	H 114
K14M96821809	== P33 ==	S 112	M90800086	== P11 ==	F 125	↑	== P31 ==	R 109	M91691015	== P15 ==	H 125
K14M96822602	== P33 ==	S 114	M90803010	== P17 ==	J 109	↑	== P31 ==	R 131	M91802006	== P9 ==	E 139
K14S90203410	== P13 ==	G 116	M90803053	== P29 ==	Q 107	M91057004	== P27 ==	P 108	M91910080	== P3 ==	B 118
↑	== P9 ==	E 112	M90804086	== P11 ==	F 132	M91058004	== P3 ==	B 147	M92002050	== P29 ==	Q 109
M70535065	== P5 ==	C 105	M90806002	== P23 ==	M 125	M91058020	== P15 ==	H 129	M92004002	== P25 ==	N 129
M71018050	== P17 ==	J 119	↑	== P33 ==	S 102	M91066004	== P27 ==	P 122	M93003021	== P13 ==	G 105
M850G2SOL	== P27 ==	P 107	M90815002	== P9 ==	E 134	M91067004	== P3 ==	B 101	M93016050	== P9 ==	E 105
M860A0FSW	== P33 ==	S 101	M90823050	== P21 ==	L 112	M91071004	== P25 ==	N 118	M93202047	== P15 ==	H 102
M90204060	== P5 ==	C 135	↑	== P29 ==	Q 106	↑	== P33 ==	S 105	M93220035	== P15 ==	H 101
M90301036	== P13 ==	G 101	M90825050	== P19 ==	K 122	M91101085	== P25 ==	N 128	M94001001	== P13 ==	G 109
M90316050	== P3 ==	B 124	M90836050	== P9 ==	E 138	M91107045	== P17 ==	J 107	M94001017	== P13 ==	G 136
M90317050	== P33 ==	S 103	M90859004	== P15 ==	H 138	M91110045	== P17 ==	J 129	↑	== P19 ==	K 153
M90323063	== P7 ==	D 116	M90883080	== P3 ==	B 106	M91111015	== P17 ==	J 113	↑	== P21 ==	L 133
M90337065	== P9 ==	E 103	↑	== P9 ==	E 128	M91117002	== P17 ==	J 111	M94001021	== P3 ==	B 145
M90403036	== P29 ==	Q 102	M90901002	== P5 ==	C 136	M91118002	== P11 ==	F 121	M94002017	== P19 ==	K 144
↑	== P31 ==	R 137	M90901045	== P23 ==	M 117	M91119002	== P9 ==	E 152	↑	== P27 ==	P 104
M90404036	== P33 ==	S 110	M90902011	== P15 ==	H 135	M91127015	== P13 ==	G 135	↑	== P7 ==	D 117
M90406064	== P9 ==	E 150	M90907010	== P17 ==	J 133	M91150003	== P5 ==	C 119	M94003017	== P3 ==	B 125
M90421050	== P13 ==	G 137	M90908003	== P13 ==	G 131	M91151010	== P17 ==	J 103	M94003021	== P25 ==	N 130
↑	== P23 ==	M 132	↑	== P15 ==	H 122	M91182080	== P3 ==	B 111	M94006052	== P17 ==	J 108
↑	== P3 ==	B 128	↑	== P23 ==	M 119	M91200086	== P11 ==	F 104	M94007017	== P19 ==	K 135
M90422050	== P17 ==	J 147	↑	== P3 ==	B 115	M91201045	== P17 ==	J 118	↑	== P3 ==	B 129
↑	== P19 ==	K 125	M90910033	== P23 ==	M 112	M91202045	== P17 ==	J 136	M94007099	== P23 ==	M 137
↑	== P23 ==	M 128	M90913001	== P17 ==	J 130	M91212015	== P17 ==	J 141	↑	== P25 ==	N 120
M90422050	== P7 ==	D 119	M90920002	== P5 ==	C 101	M91304080	== P3 ==	B 105	M94024017	== P17 ==	J 142
M90424053	== P23 ==	M 129	M90921002	== P17 ==	J 135	M91305080	== P23 ==	M 126	M94040021	== P13 ==	G 120
M90434060	== P23 ==	M 134	M90922002	== P15 ==	H 113	M91320004	== P7 ==	D 132	↑	== P19 ==	K 124
M90449037	== P7 ==	D 110	M90932015	== P23 ==	M 114	M91331004	== P5 ==	C 128	↑	== P21 ==	L 132
M90500085	== P9 ==	E 131	M90939002	== P5 ==	C 104	M91333004	== P3 ==	B 114	M95001017	== P17 ==	J 128
M90503036	== P19 ==	K 101	M90990002	== P27 ==	P 103	M91334004	== P23 ==	M 105	↑	== P19 ==	K 137
↑	== P29 ==	Q 101	↑	== P3 ==	B 130	M91384045	== P7 ==	D 109	↑	== P21 ==	L 104
M90505065	== P15 ==	H 119	↑	== P7 ==	D 104	M91500010	== P7 ==	D 131	M95002017	== P11 ==	F 117
↑	== P23 ==	M 123	↑	== P9 ==	E 142	M91501022	== P17 ==	J 121	↑	== P17 ==	J 145
M90511050	== P13 ==	G 110	M90991002	== P27 ==	P 102	M91501085	== P5 ==	C 138	↑	== P19 ==	K 105
↑	== P17 ==	J 127	M91005022	== P23 ==	M 133	M91502045	== P17 ==	J 125	M95002020	== P3 ==	B 132
↑	== P19 ==	K 138	M91007045	== P23 ==	M 130	M91506001	== P15 ==	H 107	↑	== P5 ==	C 115
↑	== P21 ==	L 107	M91008035	== P25 ==	N 135	M91512022	== P17 ==	J 126	↑	== P9 ==	E 121
↑	== P3 ==	B 121	M91010089	== P31 ==	R 132	M91553015	== P15 ==	H 117	M95002021	== P19 ==	K 115
M90511065	== P13 ==	G 107	M91011004	== P3 ==	B 117	M91572045	== P15 ==	H 132	↑	== P3 ==	B 148
M90512050	== P11 ==	F 118	↑	== P5 ==	C 132	M91602001	== P9 ==	E 140	M95002047	== P19 ==	K 103
↑	== P19 ==	K 106	↑	== P5 ==	C 146	M91602020	== P11 ==	F 127	M95003017	== P27 ==	P 120
M90512065	== P23 ==	M 135	M91013004	== P17 ==	J 102	↑	== P15 ==	H 144	↑	== P3 ==	B 134
M90513065	== P7 ==	D 114	M91053020	== P5 ==	C 117	M91602046	== P5 ==	C 121	M95003021	== P13 ==	G 112
M90522037	== P7 ==	D 106	↑	== P9 ==	E 119	M91603003	== P15 ==	H 131	↑	== P19 ==	K 116
M90522050	== P7 ==	D 108	M91054004	== P17 ==	J 148	M91606001	== P11 ==	F 102	M95004017	== P19 ==	K 150
M90523037	== P7 ==	D 125	↑	== P23 ==	M 103	↑	== P9 ==	E 141	↑	== P21 ==	L 109
M90573080	== P25 ==	N 107	↑	== P25 ==	N 103	M91606022	== P21 ==	L 135	M95004020	== P11 ==	F 134
M90600085	== P15 ==	H 108	↑	== P3 ==	B 103	M91609020	== P9 ==	E 110	↑	== P13 ==	G 121
M90604065	== P11 ==	F 115	↑	== P33 ==	S 108	M91610046	== P5 ==	C 144	↑	== P15 ==	H 121
M90631050	== P15 ==	H 133	↑	== P5 ==	C 129	M91650020	== P11 ==	F 110	↑	== P5 ==	C 134
↑	== P19 ==	K 141	M91055020	== P13 ==	G 125	↑	== P13 ==	G 134	↑	== P9 ==	E 136

索引  
INDEX-2

部品コード Parts No.	ページ Page	Fig No.	部品コード Parts No.	ページ Page	Fig No.	部品コード Parts No.	ページ Page	Fig No.	部品コード Parts No.	ページ Page	Fig No.
M95005017	↑	K 111	MF00A1392	↑	J 110	MG44E0125	↑	F 122	MH10A3508	↑	P 105
	↑	L 137	MF00A1477	↑	J 123	MG75A0265	↑	H 106	MH10A3FUS	↑	R 103
	↑	B 122	MF00A1527	↑	J 101	MG75A1476	↑	C 127	MH10A4508	↑	P 106
M95006021		L 130	MF00A1603		J 131	MH10A0160		S 104	MH10A4572		G 139
M95008021		K 151	MF00A2780		N 112	MH10A0194		C 116	MH10A4750		E 901
M95014017		G 111	MF00A8910		J 112	MH10A0245		C 148	MH10A5477		M 111
	↑	K 109	MF01E0350		F 903	MH10A0252		G 133	MH10A5910		H 115
	↑	L 125	MF01E0411		J 117	MH10A0267		H 109	MH10A6740		N 104
M95018021		G 117	MF02A0834		J 104	MH10A0283		H 120	MH10A7601		S 106
	↑	B 139	MF04A0608		R 120	MH10A0348		C 107	MH10A7740		N 111
M95021045		Q 110	MF06A1620		R 127	MH10A0364		E 127	MH10A8601		S 107
M96001001		K 134	MF10A0149		R 126	MH10A0416		E 146	MH10B1339		P 115
	↑	L 102	MF10A0181		C 131	MH10A0417		C 118	MH10B2339		P 114
M96001005		E 125	MF10A0187		C 139	MH10A0456		E 114	MH10E0193		R 117
M96001017		E 102	MF10A0325		H 118	MH10A0484		M 101	MH10E0210		C 903
M96002001		L 114	↑		E 143	MH10A0530		E 137	MH10E0285		H 901
M96002017		M 121	MF10A0553		C 140	MH10A0553		C 147	MH10E0456		E 902
M96004017		K 140	MF10A0555		C 124	MH10A0571		M 113	MH10E2519		M 104
M96008017		F 116	MF10A0709		C 137	MH10A0572		E 148	MH10E2848		E 101
M96010052		M 131	MF13A0135		N 124	MH10A0584		C 130	MH10E3519		M 127
M96011017		H 134	MF13A0192		C 111	MH10A0626		H 112	MH25A0740		N 105
M97320099		P 118	MF13A0350		C 114	MH10A0663		E 129	MH27A0148		N 133
M97358099		P 117	MF13A0377		B 143	MH10A0691		B 112	MH27A0191		C 109
M98001017		K 121	MF13A0452		F 133	MH10A0694		E 108	MH27A0225		N 125
M98002017		L 111	MF13A0456		F 103	MH10A0700		M 109	MH27A0228		H 128
M98016050		H 136	MF13A0551		C 102	MH10A0722		E 145	MH27A0230		E 117
M98021020		Q 108	MF13A0572		C 112	MH10A0729		M 118	MH27A0339		B 107
MA16A0621		J 144	MF13A0683		F 135	MH10A0742		B 104	MH27A0390		G 126
MA20A5571		J 143	MF13A0750		C 106	MH10A0750		E 109	MH27A0407		G 106
MA21A0256		H 111	MF13A0767		E 126	MH10A0760		H 143	MH27A0409		R 129
MA25A0572		J 116	MF13A0793		C 108	MH10A0763		H 116	MH27A0450		F 128
MA25A0891		J 114	MF13A0950		C 103	MH10A0830		B 113	MH27A0453		F 129
MA30A0166		Q 111	MF13A1456		F 131	MH10A0915		M 110	MH27A0456		E 123
MA30A0571		R 133	MF13A1683		F 107	MH10A0980		M 124	MH27A0500		N 123
MB02A1608		R 119	MF13A2191		C 110	MH10A0981		M 116	MH27A0508		G 119
MB25E0351		J 901	MF13A2767		F 111	MH10A1252		G 128	MH27A0516		N 127
MB50A1972		Q 105	MF13A4750		F 108	MH10A1352		G 124	MH27A0523		F 112
MB60A0201		R 128	MF13A9750		F 101	MH10A1456		E 113	MH27A0600		C 120
MB60A0366		P 109	MF13E1767		F 902	MH10A1530		M 122	MH27A0603		G 103
MB60A0620		G 115	MF13E6456		F 901	MH10A1683		G 122	MH27A0660		E 130
MB60A1620		R 110	MF17A0565		R 105	MH10A1694		E 106	MH27A0664		E 132
MB60A2352		P 110	MF17A1476		E 104	MH10A1722		E 120	MH27A0691		N 126
MB60A2620		R 108	MF17A2476		E 107	MH10A1740		G 129	MH27A0740		N 116
MB61A1571		D 121	MF20A0130		Q 104	MH10A1741		H 141	MH27A0770		F 119
MB61E0434		J 902	MF20A0229		F 120	MH10A1750		E 115	MH27A0780		N 119
MB62A4601		B 127	MF25B0123		F 123	MH10A1848		G 118	MH27A0833		E 147
ME10A7910		H 126	↑		R 102	MH10A1956		H 127	MH27A0850		G 113
ME20A0120		F 124	MF60A0700		H 142	MH10A2181		C 149	MH27A1450		F 106
ME20A0352		B 140	MF70A1180		C 133	MH10A2701		M 136	MH27A1454		E 149
ME20A0915		J 140	MF80A0780		N 106	MH10A2708		G 138	MH27A1601		J 146
ME25A0682		E 151	MG30A0700		N 134	MH10A2722		G 108	MH27A1603		G 114
ME40A0963		Q 112	MG30A0740		H 124	MH10A2740		H 140	MH27A1780		N 117
MF00A0391		J 139	MG42A0181		E 133	MH10A2956		H 139	MH27A1833		G 123
MF00A0608		R 121	MG43A0181		C 145	MH10A2FUS		R 104	MH27A1849		B 119
MF00A0750		J 115	MG43A1181		B 116	MH10A3181		C 150	MH27A2454		F 113

索引  
INDEX-3

部品コード Parts No.	ページ Page	Fig No.	部品コード Parts No.	ページ Page	Fig No.	部品コード Parts No.	ページ Page	Fig No.	部品コード Parts No.	ページ Page	Fig No.
MH27A2456	*** P9	*** E 903	MH50A0694	*** P3	*** B 126	MH50A3454	*** P21	*** L 106	MS03A0262	*** P15	*** H 110
MH27A2750	*** P9	*** E 122	MH50A0731	*** P7	*** D 120	MH50A3456	*** P21	*** L 117	MS03A0703	*** P15	*** H 103
MH27A2780	*** P25	*** N 102	MH50A0739	*** P7	*** D 107	MH50A3470	*** P7	*** D 103	MS03A1572	*** P15	*** H 105
MH27A2833	*** P13	*** G 127	MH50A0742	*** P33	*** S 109	MH50A3477	*** P17	*** J 120	MS03A2780	*** P25	*** N 101
MH27A3454	*** P13	*** G 104	↑	*** P7	*** D 111	MH50A3758	*** P3	*** B 138	MS05A0976	*** P31	*** R 112
MH27A3456	*** P11	*** F 114	MH50A0749	*** P33	*** S 901	MH50A4339	*** P3	*** B 102	MS05A1976	*** P31	*** R 111
MH27A4456	*** P11	*** F 904	MH50A0771	*** P19	*** K 143	MH50A4454	*** P19	*** K 132	MS07A0180	*** P17	*** J 134
MH27A4750	*** P11	*** F 105	MH50A0778	*** P19	*** K 129	MH50A4758	*** P19	*** K 117	MS07A0782	*** P17	*** J 105
MH27A5750	*** P11	*** F 130	MH50A0797	*** P29	*** Q 103	MH50A5339	*** P3	*** B 108	MS07A0836	*** P17	*** J 106
MH27A6476	*** P31	*** R 130	MH50A0799	*** P19	*** K 102	MH50A5601	*** P27	*** P 112	MS07A1603	*** P17	*** J 137
MH27E0190	*** P5	*** C 901	MH50A0809	*** P7	*** D 126	↑	*** P3	*** B 123	MS10A0451	*** P11	*** F 126
MH27E0383	*** P9	*** E 905	MH50A0910	*** P23	*** M 115	MH50A5758	*** P19	*** K 123	MS10A0838	*** P17	*** J 132
MH27E0484	*** P13	*** G 102	MH50A0957	*** P19	*** K 126	MH50A6339	*** P3	*** B 109	MS10A1691	*** P25	*** N 137
MH27E0550	*** P5	*** C 904	MH50A0982	*** P23	*** M 120	MH50A6601	*** P27	*** P 113	MS10A1740	*** P15	*** H 130
MH27E0580	*** P9	*** E 904	MH50A1131	*** P3	*** B 142	↑	*** P7	*** D 113	MS10A1742	*** P25	*** N 138
MH27E0688	*** P25	*** N 114	MH50A1352	*** P31	*** R 136	MH50A6758	*** P19	*** K 139	MS10A1976	*** P31	*** R 124
MH27E1148	*** P25	*** N 113	MH50A1366	*** P19	*** K 114	MH50A7339	*** P3	*** B 110	MS10A2976	*** P31	*** R 125
MH27E1688	*** P25	*** N 109	MH50A1390	*** P21	*** L 121	MH50A7601	*** P19	*** K 107	MS14A0553	*** P5	*** C 125
MH27E2688	*** P25	*** N 115	MH50A1407	*** P19	*** K 127	MH50A7758	*** P19	*** K 142	MS14A0682	*** P9	*** E 118
MH27E3688	*** P25	*** N 110	↑	*** P19	*** K 156	MH50A8339	*** P3	*** B 135	MS14A1180	*** P5	*** C 126
MH27E4688	*** P25	*** N 132	MH50A1408	*** P21	*** L 140	MH50A8601	*** P19	*** K 120	MS14E0180	*** P5	*** C 902
MH27E5688	*** P25	*** N 136	MH50A1454	*** P3	*** B 137	MH50A8758	*** P19	*** K 145	MT60A0802	*** P5	*** C 143
MH40A0556	*** P5	*** C 141	↑	*** P31	*** R 902	MH50A9758	*** P21	*** L 105			
MH40A1397	*** P31	*** R 106	MH50A1456	*** P19	*** K 147	MH50B0758	*** P21	*** L 108			
MH50A0165	*** P3	*** B 144	MH50A1470	*** P7	*** D 101	MH50B1758	*** P21	*** L 113			
MH50A0191	*** P5	*** C 113	MH50A1476	*** P7	*** D 129	MH50B2722	*** P21	*** L 115			
MH50A0228	*** P19	*** K 104	MH50A1477	*** P21	*** L 134	MH50B3758	*** P21	*** L 116			
MH50A0352	*** P21	*** L 118	MH50A1484	*** P21	*** L 139	MH50B4758	*** P21	*** L 120			
↑	*** P31	*** R 118	MH50A1508	*** P27	*** P 119	MH50B5758	*** P21	*** L 123			
MH50A0359	*** P7	*** D 105	↑	*** P7	*** D 123	MH50B6758	*** P21	*** L 128			
MH50A0361	*** P7	*** D 118	MH50A1571	*** P19	*** K 110	MH50B7758	*** P21	*** L 129			
MH50A0366	*** P19	*** K 108	MH50A1603	*** P19	*** K 113	MH50E0849	*** P21	*** L 110			
MH50A0408	*** P21	*** L 138	MH50A1613	*** P31	*** R 901	MH50E1599	*** P27	*** P 902			
MH50A0416	*** P17	*** J 124	MH50A1639	*** P19	*** K 136	MH50E1849	*** P21	*** L 119			
MH50A0417	*** P23	*** M 106	MH50A1682	*** P19	*** K 133	MM10A1479	*** P31	*** R 123			
MH50A0418	*** P3	*** B 120	MH50A1739	*** P7	*** D 130	MM11A0245	*** P5	*** C 123			
MH50A0429	*** P3	*** B 146	MH50A1742	*** P7	*** D 127	MM11A0702	*** P5	*** C 122			
MH50A0434	*** P7	*** D 122	MH50A1767	*** P19	*** K 148	MN10A0135	*** P25	*** N 122			
MH50A0454	*** P3	*** B 133	MH50A1778	*** P21	*** L 126	MN10A1456	*** P9	*** E 124			
↑	*** P31	*** R 135	MH50A1920	*** P19	*** K 149	MN35A0628	*** P15	*** H 137			
MH50A0456	*** P19	*** K 131	MH50A1957	*** P19	*** K 155	MN52A1245	*** P5	*** C 142			
MH50A0470	*** P3	*** B 131	MH50A2339	*** P23	*** M 102	MN60A0620	*** P25	*** N 131			
MH50A0476	*** P19	*** K 146	MH50A2454	*** P21	*** L 127	MN70A1780	*** P13	*** G 130			
MH50A0477	*** P7	*** D 112	MH50A2456	*** P21	*** L 101	↑	*** P15	*** H 123			
MH50A0484	*** P21	*** L 136	MH50A2470	*** P7	*** D 102	MN70A2456	*** P11	*** F 109			
MH50A0527	*** P19	*** K 152	MH50A2476	*** P17	*** J 122	MP40A1740	*** P25	*** N 108			
MH50A0567	*** P31	*** R 134	MH50A2477	*** P19	*** K 154	MS01A0155	*** P9	*** E 144			
MH50A0571	*** P7	*** D 115	MH50A2508	*** P27	*** P 901	MS01A1976	*** P31	*** R 113			
MH50A0598	*** P27	*** P 121	MH50A2523	*** P21	*** L 124	MS02A0128	*** P31	*** R 101			
MH50A0613	*** P31	*** R 107	MH50A2571	*** P19	*** K 112	↑	*** P9	*** E 135			
MH50A0639	*** P19	*** K 128	MH50A2682	*** P21	*** L 122	MS02A0463	*** P15	*** H 902			
MH50A0640	*** P7	*** D 124	MH50A2758	*** P3	*** B 136	MS02A0479	*** P31	*** R 122			
MH50A0650	*** P7	*** D 128	MH50A2767	*** P19	*** K 130	MS02A0976	*** P31	*** R 116			
MH50A0682	*** P9	*** E 111	MH50A2920	*** P21	*** L 131	MS02A1976	*** P31	*** R 115			
MH50A0683	*** P21	*** L 103	MH50A3339	*** P27	*** P 101	MS02A2976	*** P31	*** R 114			

MEMO

A large rectangular area containing numerous horizontal dotted lines for writing.



お問い合わせは下記へどうぞ

FAシステム事業本部 機器計画部 駆動機器グループ 〒100-8310 東京都千代田区丸の内2-7-3 (東京ビル)  
代表電話番号 (03) 3218-6631 代表FAX番号 (03) 3218-6823



FACTORY AUTOMATION SYSTEM GROUP

2-7-3, Marunouchi Chiyoda-ku Tokyo 100-8310, Japan

Fax : +81-3-3218-6821